



STAINLESS STEEL DEMO TABLE & CEILING MOUNTED DEMO MIRROR



Shown with Optional Drawer

DEMO TABLE

MODEL #	Table Size W x L	Mirror Frame "M"	Wt.	Cu.
VSS-DT-365	36" x 60"	25 1/2" x 50 1/2"	275 lbs.	18
VSS-DT-366	36" x 72"	25 1/2" x 62 1/2"	305 lbs.	23



CEILING MOUNTED MIRROR

MODEL #	"L" O.A. Size	Mirror Frame "M"	Wt.	Cu.
MI-48	54"	25 1/2" x 48 1/4"	125 lbs.	7
MI-60	66"	25 1/2" x 60 1/4"	160 lbs.	10



Item #: _____ **Qty #:** _____

Model #: _____

Project #: _____

FEATURES:

Fully adjustable glass mirror tilts to desired position.

Locking Knob for securing mirror's position.

Glass Mirror

DEMO TABLE:

Top is furnished with a 2" x 1" square die embossed NO-DRIP countertop edge with a 1/2" return on 4 sides.

Pre-engineered welded angle adapters insure ease of future drawer installation.

36" wide table supplied with THREE hat channels stud welded to reinforce and maintain a level working surface.

Aluminum die cast "leg-to-shelf" clamp secures shelf to leg eliminating unsightly nuts and bolts. Undershelf is adjustable.

CEILING MOUNTED MIRROR:

Tubular stainless steel mounting support.

CONSTRUCTION:

All TIG welded. Exposed weld areas polished to match adjacent surfaces.

Entire top mechanically polished to a satin finish. Countertop edge polished to a MIRROR finish (Demo Table Only).

Top is sound deadened.

Roll formed embossed galvanized hat channels are secured to top by means of structural adhesive and weld studs (Demo Table Only).

Gussets welded to support hat sections (Demo Table Only).

MECHANICAL:

Mirror tilts to desired position.

MATERIAL:

Square tubular mirror frame is 18 ga., 304 type Stainless steel.

Glass Mirror

DEMO TABLE:

TOP: 14 gauge type "304" stainless steel.

SHELF: 18 gauge type "430" stainless steel.

LEGS: Legs are 1 5/8" diameter tubular, 16 gauge stainless steel '304' type series. 1" adjustable stainless steel bullet feet.

CEILING MOUNTED MIRROR:

1 5/8" diameter 16 gauge type "304" stainless steel posts welded to ceiling mount channels

PRINT REQUIRED - SPECIFY POST LENGTH



Customer Service Available To Assist You **1-800-645-3166** 8:30 am - 8:00 pm E.S.T.

Email Orders To: customer@advancetabco.com. For Smart Fabrication™ Quotes, Email To: smartfab@advancetabco.com or Fax To: 631-586-2933

NEW YORK
Fax: (631) 242-6900

GEORGIA
Fax: (770) 775-5625

TEXAS
Fax: (972) 932-4795

NEVADA
Fax: (775) 972-1578

DETAILS and SPECIFICATIONS

TOL ± .500"

ALL DIMENSIONS ARE TYPICAL

DEMO TABLE

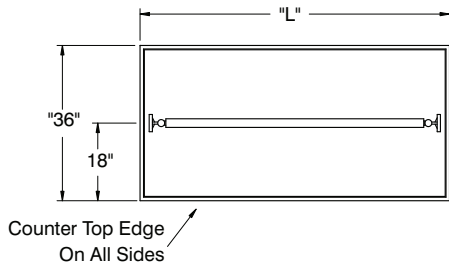

COUNTERTOP EDGE DETAIL

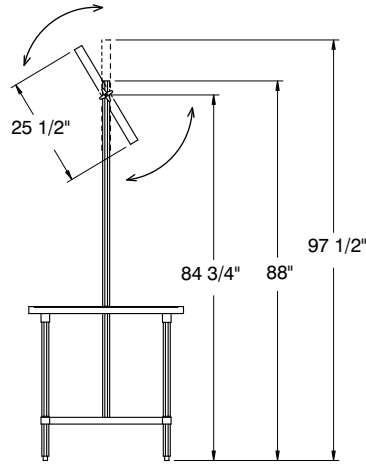
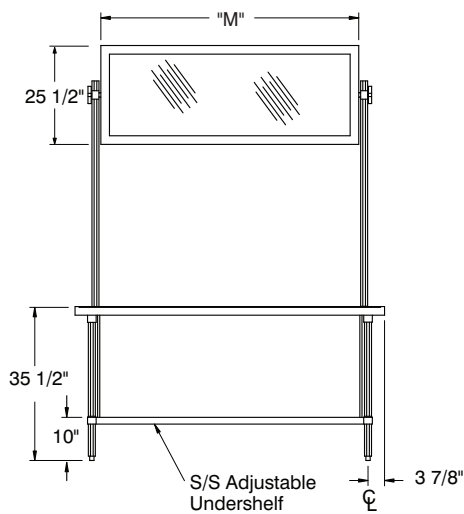
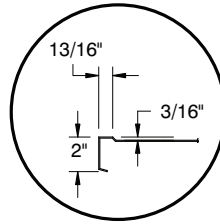

CEILING MOUNTED MIRROR

PRINT REQUIRED

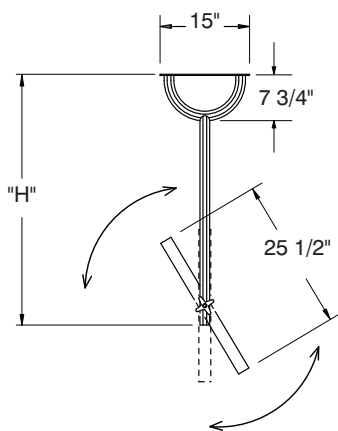

"H" Dimension must be provided

