



COUNTER TOP ELECTRIC BAKE & ROAST OVENS

Job _____ Item # _____

ELECTRIC COUNTER TOP OVENS



Model P48S

- Model P48S
- Model P48BL

STANDARD FEATURES

- P48S @ 4300 watts in 208V or 220-240V
- Two independent, operator controlled cook/bake chambers each with a separate set of controls
- Two 60-minute electric timers with continuous ring, audible alarms and manual shut-offs (one for each chamber)
- 150°-550°F Temperature range (65°-288°C)
- Corderite hearth decks
- 7 1/2" Deck height (190mm)
- All stainless steel exterior
- Unitized, welded, aluminized steel interior
- Fully insulated
- Limited one year parts & labor warranty

SPECIFICATIONS

The P48S Bake & Roast electric counter top ovens feature two independent, operator controlled baking chambers with 7 1/2" (190mm) deck heights and hearth stone decks making them ideal for baking and roasting.

The brick lined option adds top heat intensity, speeds recovery and increases production. The brick lined option may be easily installed in the standard P44S either in the field or factory. Hearth stone decks are easily removable for cleaning or replacement.

The P48S features two sets of controls — one set for each bake chamber. Each set consists of a 60-minute electric timer with audible alarms and manual shut-offs and a 150-550° F (65-288°C) thermostat.

The exterior front, sides, top and door are fabricated of heavy gauge type 430 stainless steel with a #4 finish. Door handle is constructed of tubular stainless steel. Exteriors measures 26" wide (660mm) by 28" deep (711mm) by 28 1/2" tall (724mm) overall.

The interiors are constructed of high heat aluminized steel, welded to form a single unitized body. The entire oven is insulated with 1 1/2" thick (38mm) industrial grade insulation. Each hearth stone deck measures 20 3/4" (527mm) by 20 3/4" (527mm).

Incluy, tubular heating elements provide top and bottom heat with up to 4300 watts in 208V or 220-240V, single or three phase. International voltages available. Ovens are stackable.

1 Year limited parts and labor warranty included.

OPTIONS & ACCESSORIES

- 4" (102 mm) adjustable legs
- Stainless steel stand with or without casters
- Stacking kit
- Brick lined conversion kit — standard on P48BL
- Steel decks in lieu of hearth stone
- Interior lights
- International voltages
- Glass windows in door(s)

CERTIFICATIONS



BAKERS PRIDE OVEN COMPANY, INC.
30 Pine Street, New Rochelle, NY 10801
914/576-0200 • 1-800-431-2745 • fax 914/576-0605
www.bakerspride.com

Continuous product improvement is a policy of Bakers Pride Oven Company. Therefore, specifications and design are subject to change without notification

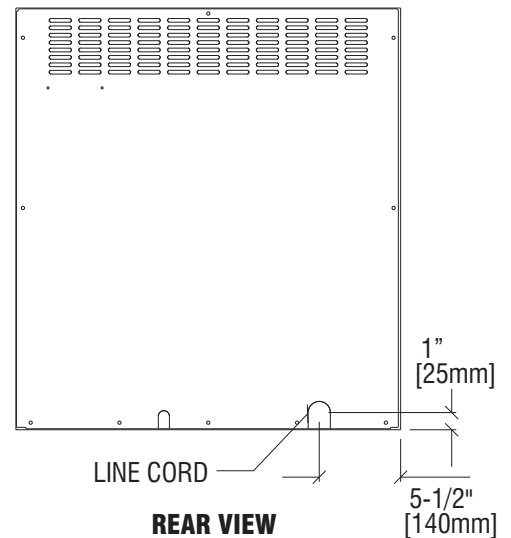
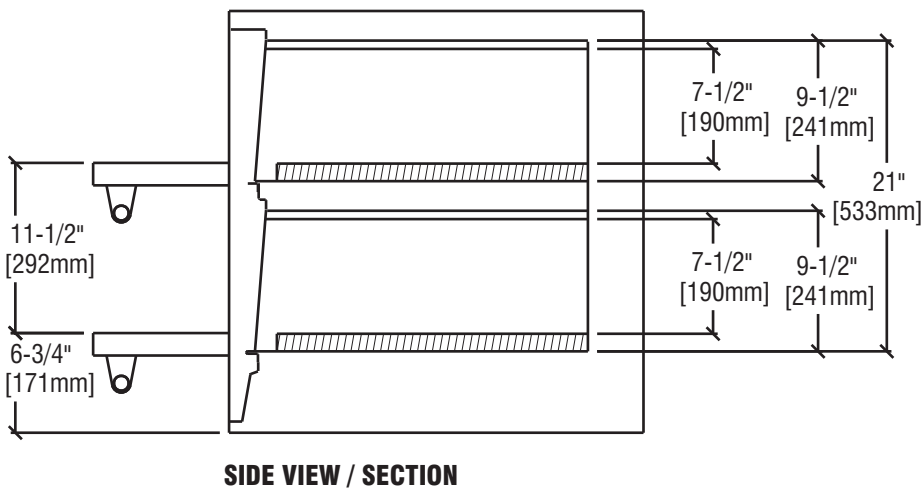
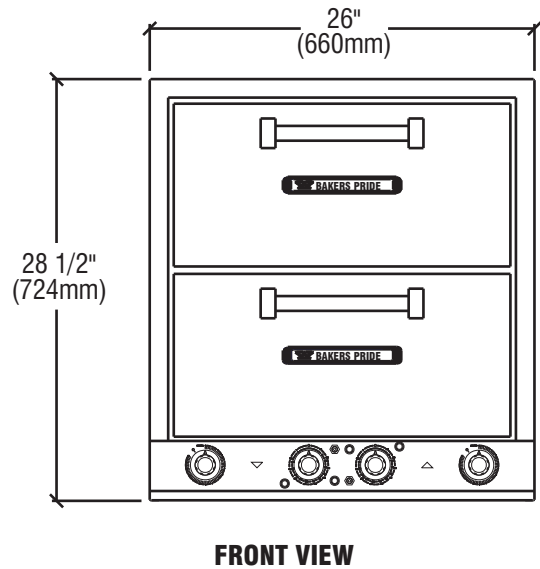
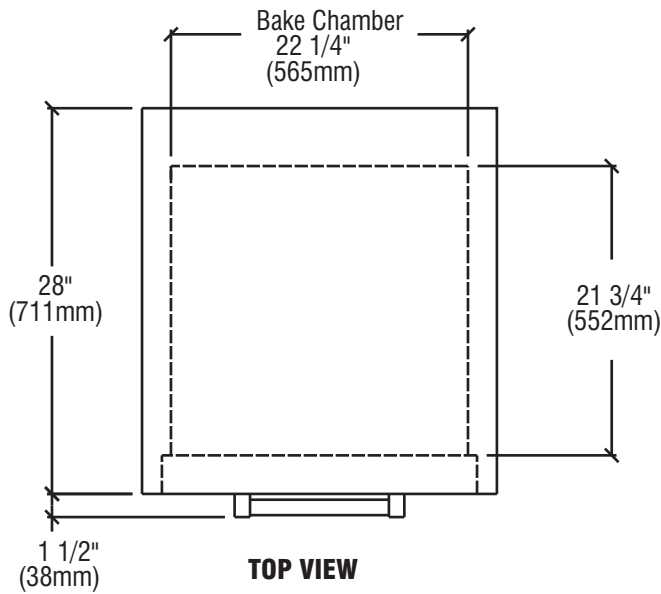

ALL DIMENSIONS NOMINAL

Model	Shipping Weight		Carton Dimensions				Crate Size		Cubic Feet	Cubic Meter
	Lbs.	Kilos	Width	Depth	Height	Cubic Feet	Cubic Meter			
	Inches	mm	Inches	mm	Inches					
P48S	278	126	30	762	32	813	32	813	17.7	.51
P48BL	288	131	30	762	32	813	32	813	17.7	.51

Under 500 lbs = Shipping Class # 70

Model	WATTS	VOLTAGE	PHASE	AMPS	NEMA Plug #			
					USA	Canada	UK	Europe
P48S/BL	4300	208	1 & 3	20.7 & 20.7		6-30P		
P48S/BL	4300	220-240	1 & 3	18.7 & 18.7				

Each oven requires a separate electrical connection.
 1 Phase and Canada include cord and plug
 3 Phase and International voltages has no line cord

Model	Deck Size		# Decks	# Cook Chambers	Overall Dimensions					
	Inches	mm			Width		Depth		Height	
	Inches	mm			Inches	mm	Inches	mm	Inches	mm
P48S/BL	20 3/4 x 20 3/4	527x527	2	2	26	660	28	711	28 1/2	724

	Non-Combustible Construction*		Combustible Construction**	
	Inches	mm	Inches	mm
Left Side	3	76	3	76
Right Side	3	76	3	76
Rear	3	76	3	76

* In European Community Countries and North America. In NON-COMBUSTIBLE locations only.
 ** In European Community Countries only in COMBUSTIBLE locations. NOT for North America.



6-30P



BAKERS PRIDE OVEN COMPANY, INC.
 30 Pine Street, New Rochelle, NY 10801
 914/576-0200 • 1-800-431-2745 • fax 914/576-0605
 www.bakerspride.com

Continuous product improvement is a policy of Bakers Pride Oven Company. Therefore, specifications and design are subject to change without notification

TSW:11/07