



BEVERAGE-AIR

3779 Champion Blvd., Winston-Salem, NC 27105
1-888-845-9800 Fax# 1-336-245-6453
<http://www.Beverage-Air.com>

Item No. _____
Quantity _____

DEEP & SHALLOW WELL HORIZONTAL COOLERS DW/SF WINE SERIES

MODELS:
DW49-WINE
DW64-WINE
DW79-WINE
DW94-WINE
SF34-WINE

Commercial Refrigeration Equipment General Specification

3 Year Parts/Labor Warranty Additional 2 Year Compressor Warranty

DEEP & SHALLOW WELL—WINE SERIES HORIZONTAL BOTTLE COOLERS

Deep Well horizontal coolers include 4 (four) self-contained models in widths of 50", 65", 80" and 95". One shallow well model (SF34) is available in width of 35".

Used for storage of red or white wines.

CABINET CONSTRUCTION

Exteriors of both deep well and shallow well models include attractive, wear-resistant vinyl on steel in black finish. Stainless steel options are available.

Bottle cap opener and cap catcher is standard with all models.

Tops of both deep well and shallow well models include easy glide, stainless steel lids and stainless steel counter top with integral glass stops. Optional glass lids, when specified, come with interior lighting. Lid locks are optionally available.

Standard interior metal is galvanized steel. Stainless steel interior is optionally available. Adjustable dividers included are epoxy coated steel wire.

Environmentally friendly foamed-in-place CFC and HCFC-free polyurethane insulation enhances the structural strength of the cabinet and helps increase energy efficiency.

REFRIGERATION

Forced air refrigeration systems provide ample capacity to chill and hold wine temperatures between 40°F and 60°F for storage of red or white wines. Adjustable thermostats standard.

Refrigerant R134a used in systems is CFC and HCFC-free for compliance to environmental safety concerns. Condensate elimination is automatic and non-electric.

ELECTRICAL

Units wired at factory and ready for connection to a 115/60/1 phase, 15 amp dedicated outlet. 8' long cord and plug set included.



DW49-B-WINE



DW64-B-WINE



DW79-B-WINE



DW94-B-WINE



*Note: Not all markings may apply to all model variations.

Available From:

Model Specified _____	Store# _____
Location _____	Quantity _____



ELECTRICAL CONNECTION
 Units pre-wired at factory and include 8' long cord and plug set.



Deep & Shallow Well Horizontal Bottle Coolers—Wine Series
Models: DW49-WINE, DW64-WINE, DW79-WINE, DW94-WINE, SF34-WINE

MODEL	DW49-WINE	DW64-WINE	DW79-WINE	DW94-WINE	SF34-WINE
EXTERNAL DIMENSIONAL DATA					
Length Overall (inches)	50"	65"	80"	95"	35"
Length Overall (mm)	1270	1651	2032	2413	889
Depth Overall (inches)	26 1/2"	26 1/2"	26 1/2"	26 1/2"	26 1/2"
Depth Overall (mm)	673	673	673	673	673
Height Overall—(inches)	33 7/8"	33 7/8"	33 7/8"	33 7/8"	33 7/8"
Height Overall—(mm)	860	860	860	860	860
Number of lids	2	2	3	4	1
INTERNAL DIMENSIONAL DATA					
NET Capacity (cubic ft.)	13.3	18.5	24.1	28.5	7.5
NET Capacity (Liters)	377	524	682	807	212
Internal Length Overall (inches)	46"	61"	76"	91"	31"
Internal Length Overall (mm)	1168	1549	1930	2311	787
Internal Depth Overall (inches)	22 1/2"	22 1/2"	22 1/2"	22 1/2"	22 1/2"
Internal Depth Overall (mm)	572	572	572	572	572
Internal Height Overall (inches)	27"	27"	27"	27"	18 1/2"
Internal Height Overall (mm)	686	686	686	686	470
Number of dividers	3	4	5	6	2
12 oz. bottle capacity	17 1/2 cases	25 1/4 cases	32 cases	39 cases	9 1/3 cases
12 oz. can capacity	23 3/4 cases	34 3/4 cases	45 3/4 cases	55 3/4 cases	11 1/2 cases
ELECTRICAL DATA					
Full Load Amperes 115/60/1	6.3	6.3	9.5	9.5	4.5
ENERGY CONSUMPTION (KWH)					
	3.0	3.52	3.77	4.32	4.4
REFRIGERATION DATA					
Horsepower	1/3	1/3	1/2	1/2	1/5
WEIGHT DATA					
Gross Weight (Crated lbs)	378	331	388	468	214
Gross Weight (Crated kg)	172	150	176	212	97

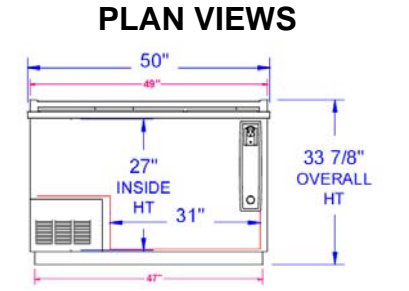

DW49 FRONT

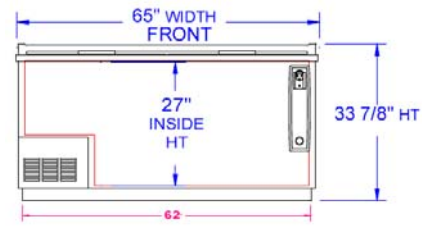

DW64 FRONT

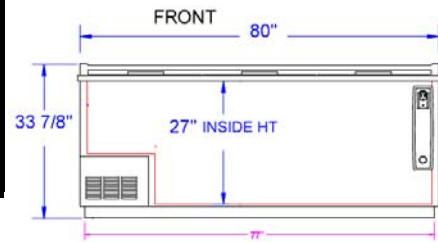

DW79 FRONT



*Note: Not all markings may apply to all model variations.

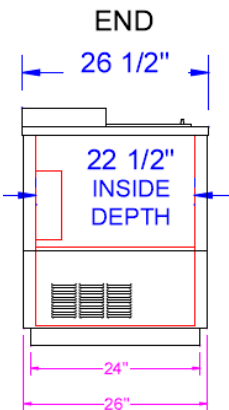

COMMON END

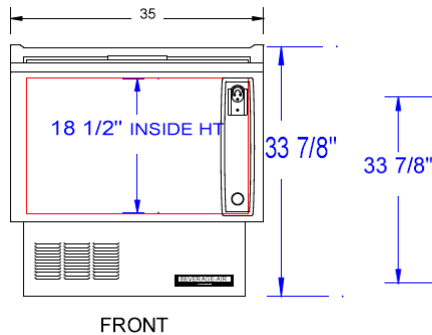

SF34 FRONT

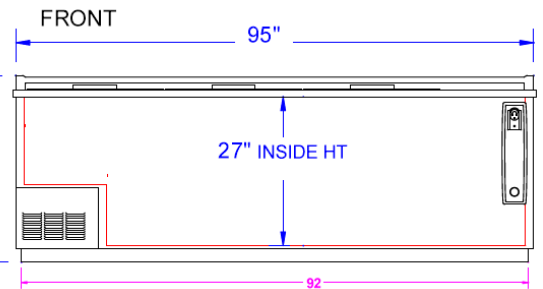

DW94 FRONT

BEVERAGE-AIR® CORPORATION