

## Combo Carts™

### For Sheet Pans and Gastronorm Food Pans

#### Double Compartment

Models CMB1826, CMB1826SP (Security Package)

#### Single Compartment

Models CMB1826L, CMB1826LSP (Security Package)

#### Features & Benefits



- These carts will accept pans straight from the oven and hold them hot for hours! A "hot" alternative to metal carts that adds up to performance and cost savings.
- Easy-to-adjust aluminum rails (12 pairs per compartment) make it versatile enough to accept a wide variety of menu items baked on sheet pans or cooked in hotel pans.
- Each compartment holds:
  - 12 each 18" x 26" (46 x 66 cm) sheet pans
  - 24 each 13" x 18" (33 x 46 cm) sheet pans
  - or 12 each GN 1/1 Food Pans, 2 1/2" (6,5 cm) deep
- Durable one-piece, double-wall, molded polyethylene construction is impact resistant, easy to clean and won't dent, crack, rust, chip or break.
- Thick foamed-in place polyethylene insulation and an airtight gasket seal helps to maintain hot food temperatures for hours.
- Full swing doors open 270° to the side, offering complete access to open compartments.
- Recessed corrosion-free stainless steel hardware hinges and latches are long lasting and prevent accidental openings.
- Molded-in full-length handle is located on the back for easy maneuvering.
- Rounded corners protect walls and furniture during transport.
- Vent cap allows steam to be released and keeps menu items from becoming soggy.
- Two each 5" (12,7 cm) swivel casters w/ brakes and 2 each 10" (25,4 cm) Easy Wheels ensure smooth transport.
- Available with optional security hardware package for maximum security applications.
- Non electrical.
- Minimal assembly required. Rails are boxed and shipped inside compartment.
- Available in 2 colors.

Item No. \_\_\_\_\_

Specifier Identification No. \_\_\_\_\_

Model No. \_\_\_\_\_

Quantity \_\_\_\_\_



CMB1826



CMB1826L



Each compartment holds up to 12 each full size 2 1/2" (6,5 cm) deep GN Food Pans (2 pans per rail).



Holds up to 12 each 18" x 26" (46 x 66 cm) sheet pans or 24 each 13" x 18" (33 x 46 cm) sheet pans per compartment.



Easy-to-adjust rails.

# Combo Carts™

## For Sheet Pans and Gastronorm Food Pans

### Double Compartment

Models CMB1826, CMB1826SP (Security Package)

### Single Compartment

Models CMB1826L, CMB1826LSP (Security Package)

Item No. \_\_\_\_\_

Specifier Identification No. \_\_\_\_\_

Model No. \_\_\_\_\_

Quantity \_\_\_\_\_

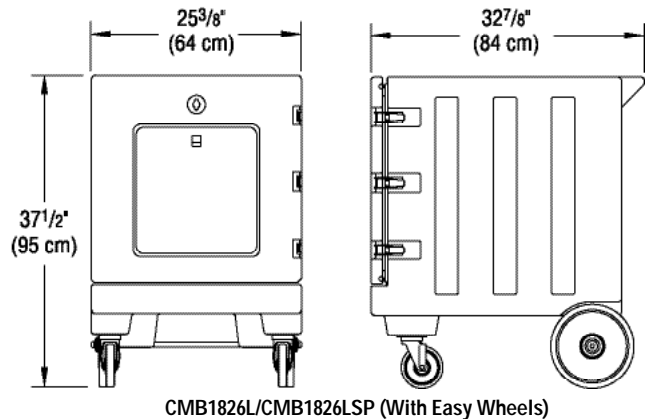
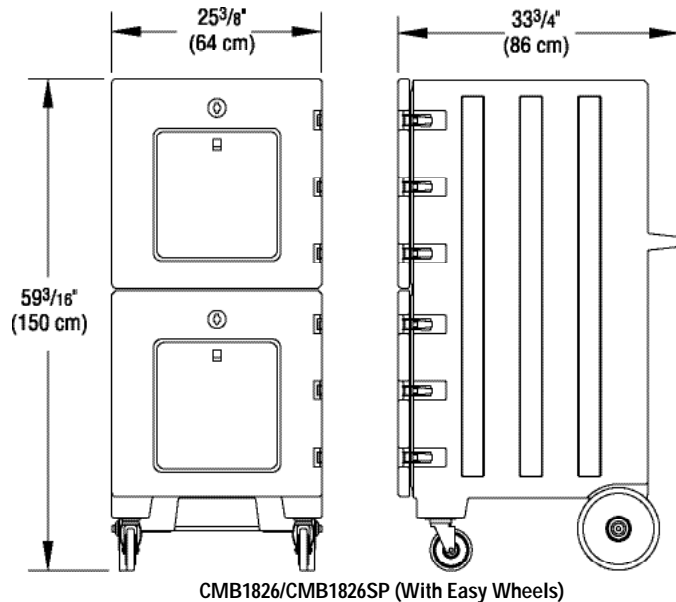

## Specifications

Dimension Tolerance: +/- 1/4" (0,64 cm)

Code	Description	Interior Dimensions W x D x H	Exterior Dimensions W x D x H	Case lbs./cube Kg/m <sup>3</sup>
<b>Without Security Package</b>				
CMB1826	Combo Cart w/ 2 compartments	22" x 26 1/2" x 22 1/2" (56 x 68 x 57 cm)	25 3/8" x 33 3/4" x 59 3/16" (64 x 86 x 150 cm)	226 (32.70) 103 (0,9)
CMB1826L	Combo Cart w/ 1 compartment	22" x 26 1/2" x 22 1/2" (56 x 68 x 57 cm)	25 3/8" x 32 7/8" x 37 1/2" (64 x 84 x 95 cm)	136 (21.16) 62 (0,6)
<b>With Security Package</b>				
CMB1826SP	Combo Cart w/ 2 compartments	22" x 26 1/2" x 22 1/2" (56 x 68 x 57 cm)	25 3/8" x 33 3/4" x 59 3/16" (64 x 86 x 150 cm)	226 (32.70) 103 (0,9)
CMB1826LSP	Combo Cart w/ 1 compartment	22" x 26 1/2" x 22 1/2" (56 x 68 x 57 cm)	25 3/8" x 32 7/8" x 37 1/2" (64 x 84 x 95 cm)	136 (21.16) 62 (0,6)

## Architect Specs

The non-electrical cart for transporting hot trays and sheet pans shall be a Combo Cart, Model..., manufactured by Cambro Mfg. Co., Huntington Beach, CA 92648 U.S.A. It shall be made of one-piece, seamless, double-wall, high-density, polyethylene and shall be injected with polyurethane foam. It shall have rounded corners and a full-length, molded-in handle in the back. It shall have full swing doors that open 270° to the side. It shall be available with 1 or 2 compartments. It shall have 24 easy-to-adjust aluminum rails for each compartment. Each compartment shall hold 12 each 18" x 26" (46 x 66 cm) sheet pans, 24 each 13" x 18" (33 x 46 cm) sheet pans or 12 each GN 1/1 Food Pans, 2 1/2" (6,5 cm) deep. It shall have a vent cap on the outside of each compartment. It shall have 2 each 5" (12,7 cm) swivel casters with brakes and 2 each 10" (25,4 cm) Easy Wheels. It shall be available with security hardware for maximum-security applications. It shall require minimal assembly. It shall be available in 2 colors.

## Standard Colors

- Gray (180)       Dark Brown (131)