

Champion[®]

The Dishwashing Machine Specialists

Project _____
Item No. _____
Quantity _____

STANDARD FEATURES

- Three built-in chemical dispensing pumps
- Electric tank heater
- Built-in controls
- Upper and lower wash and rinse spray system
- Stainless steel wash and rinse chamber
- Polypropylene conveyor
- Right-to-left or left-to-right operation
- Two splash curtains

CG4/CG6

Pass Through Series
Fully Automatic
Glasswashing Machine



CG4/CG6 GLASSWASHER



OPTIONS & ACCESSORIES

- CG46C Waste Sink
- CG47 Drain Tray and Waste Collector
- CG12 SST Splash Guards (CG4)
- CG24 SST Splash Guards (CG6)
- CG48 SST Back Panel (CG4)
- CG72 SST Back Panel (CG6)
- Kit 264 Washdown Hose
- Kit 332 Casters, set of 4, 2 locking, 2 regular

SPECIFIER STATEMENT

Specified unit will be Champion model CG4 or CG6 pass-through conveyor type glasswasher.

Features include detergent, sanitizer and rinse aid pump, upper & lower wash/rinse arms, cold water final rinse, polypropylene conveyor, two splash curtains, processes 2,000 glasses/hr.

Warranty: 1 year parts, 90 day labor.

Champion Industries, Inc.
P. O. Box 4149, Winston-Salem, NC 27115
Tel: 800/532-8591 Fax: 336/661-1979
www.championindustries.com

CG4/CG6

Pass Through Series
Fully Automatic
Glasswashing Machine

Champion®

The Dishwashing Machine Specialists

Dimensions shown in inches

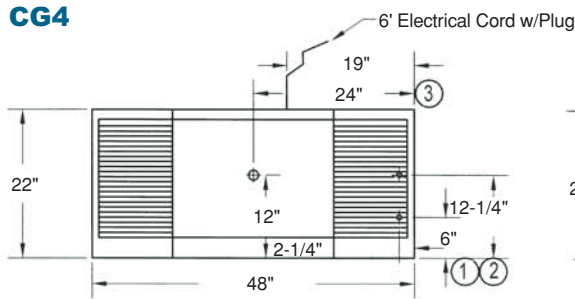

Plan View

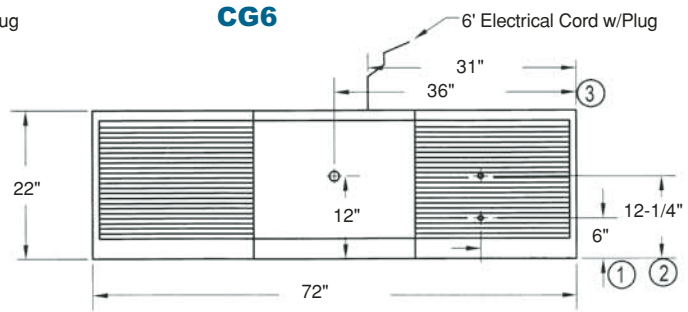

Plan View

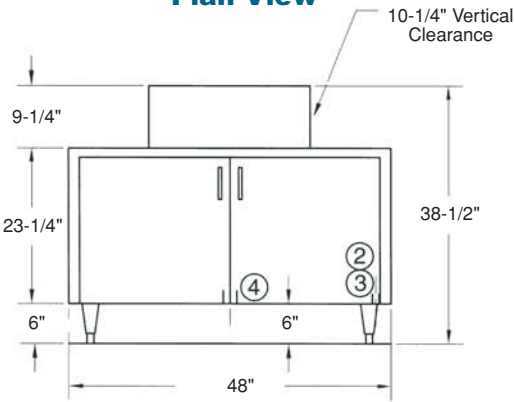

Front View

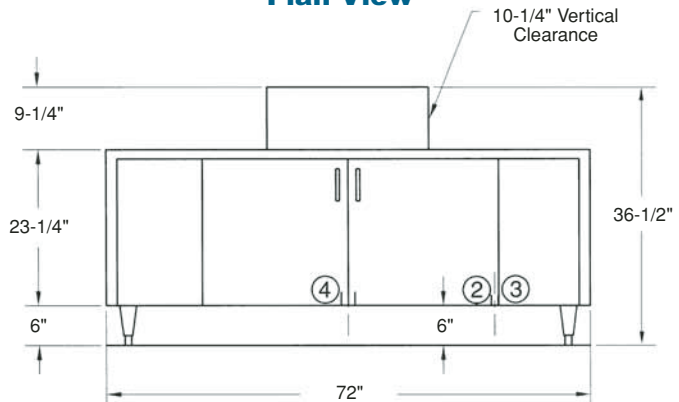

Front View

Note: Both Doors 21-1/2" High
22" Wide

Utilities	
	*Electrical 208-230/60/1, 15 AMP
1	Hot Water 1/2" IPS. Flow pressure 25-95 psi
2	Cold Water 1/2" IPS. Flow pressure 25-95 psi
3	Drain 1-1/2" tailpiece. Connect to drain size according to local plumbing code.

	Uncrated		Crated	
	CG4	CG6	CG4	CG6
Height*	38-1/2"	38-1/2"	49"	49"
Width	48"	72"	63"	76-1/2"
Depth	22"	22"	27-1/2"	27-1/2"
Ship Wt. Lbs.	225	285	255	325

*Adjustable foot height 1-3/4"

*** Note:** CG4/CG6 models supplied with 4 ft. plug-in cord (NEMA 6-15P).

Warning: Plumbing and electrical connections should be made by qualified workmen who will observe all the applicable plumbing, sanitary and safety codes.

SPECIFICATIONS

Capacity (hr)	2-1/2" glasses/hr.	2000
Water consumption	Cold Water (approx.)	2.8 gpm
	Hot Water (initial fill)	2.8 gpm
	(Max. use – approx. 10 gph)	
Temperatures °F	Inlet water (hot) min/max	145/160
	Inlet water (cold)	75
Heating	Tank heat, electric, (kW)	3
Clearance	Through machine (inches)	10-1/4"
Conveyor Speed	Inches per minute	14

Due to an ongoing value analysis program at Champion, specifications contained in this catalog are subject to change without notice.

Champion Industries, Inc., P. O. Box 4149, Winston-Salem, NC 27115 • 800/532-8591 • Fax: 336/661-1979 • www.championindustries.com