



Energy
MIZER

GW-100 / GL-C
120V / 208/230V
Chemical Sanitizing
Undercounter Glasswasher



FEATURES:

- Cleans and sanitizes up to 1000 2-1/2" glasses per hour.
- Hands-free glass activated on/off stop is safe and convenient.
- Independent upper and lower wash and rinse arms ensure superior results.
- 120V (GW-100) with built-in 1.25kW electric tank heater maintains the recirculated wash water to the recommended 140°F wash temperature.
- 208-230V (GL-C) with built-in 3kW electric tank heater maintains the recirculated wash water to the recommended 140°F wash temperature.
- Compatible with both Iodine and Chlorine Sanitizers.
- Simple controls for operation and cleaning.
- All stainless steel construction assures trouble free service and a long life.
- Optional rinse temperature allows flexible sanitizing options.
- Poly Pro™ circular conveyor is extremely durable and reduces chipping and breakage of glassware.
- Double wall construction for quiet back bar operation.
- Internal chemical storage.
- Built-in chemical pumps with primer switches.

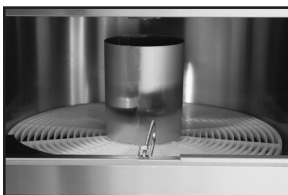

Stainless steel wash/rinse chamber.



Independent spray arms blast water from the top and bottom for optimum cleaning, sanitizing and rinsing.





WARNING: Plumbing connections must be made by a qualified service company who will comply with all available Federal, State, and Local Health, Plumbing and Safety codes.

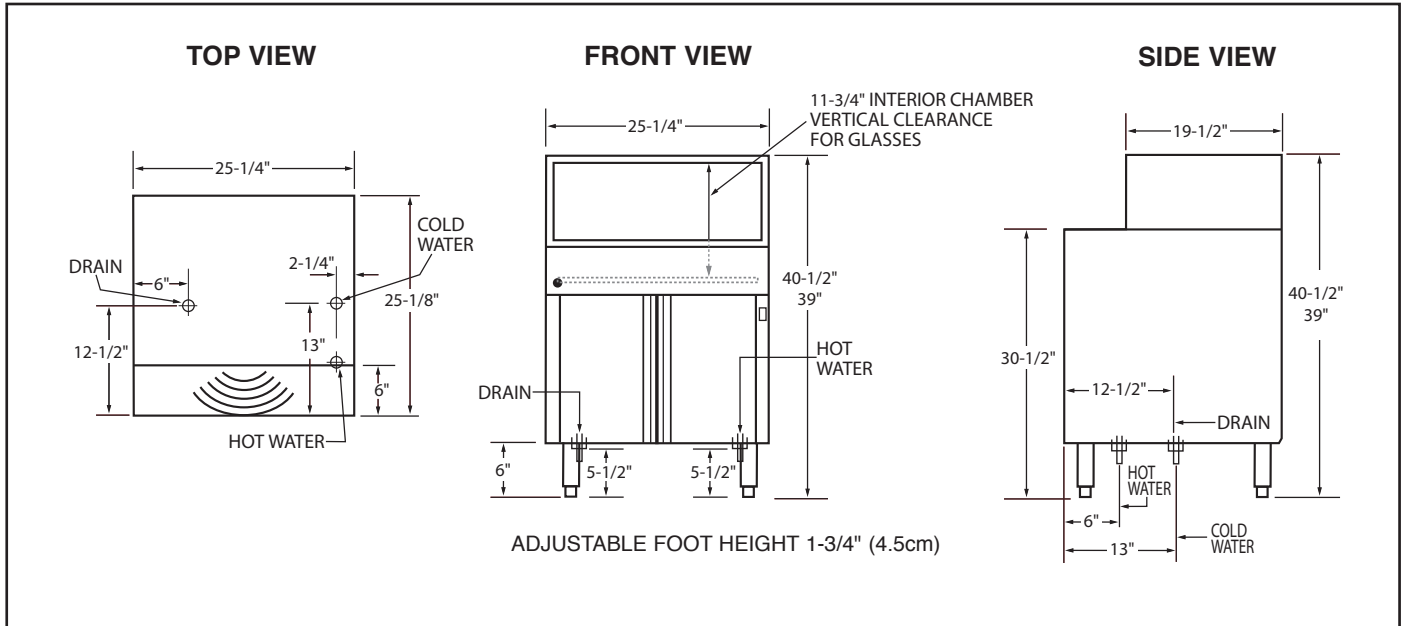

Specifications:

| MODEL GW-100 AND MODEL GL-C | USA | METRIC | | USA | METRIC |
|--|---------|------------|------------------------------------|--------------------------|------------------|
| OPERATING CAPACITY (2-1/2") GLASSES PER HOUR | 1000 | 1000 | DIMENSIONS | DEPTH | 25-1/8" (63.8cm) |
| OPERATING TEMPERATURES | | | | WIDTH | 25-1/4" (64.1cm) |
| INLET WATER. (HOT) RECOMMENDED | 140°F | (60°C) | HEIGHT | 39"-40-1/2" (99-102.8cm) | |
| INLET WATER. (COLD) | 75°F | (24°C) | MAXIMUM CLEARANCE FOR GLASSWARE | 11-3/4" (29.84cm) | |
| WATER CONSUMPTION | | | ELECTRICAL RATING | VOLTS | AMPS |
| HOT WATER (INITIAL FILL) | 3 GAL | (11.25 L) | GW-100 | 120/60/1 | 11 |
| HOT WATER PER HOUR (MAX) | 12 GAL | (45.42 L) | GL-C | 208-230/60/1 | 11.5-13 |
| COLD WATER PER MINUTE (APPROX) | 2.8 GPM | (10.6 LPM) | TANK HEATER - GW-100 | 1.25kW | |
| WATER REQUIREMENTS | | | TANK HEATER - GL-C | 3kW | |
| HOT WATER INLET | 1/2" | (1.27cm) | SHIPPING WEIGHT APPROXIMATE | 156# | (71kg) |
| COLD WATER INLET | 1/2" | (1.27cm) | | | |
| DRAIN (MAX) | 1-1/2" | (3.81cm) | | | |

Summary Specifications: Model GW-100 (120V) and Model GL-C (208/230)

The **GW-100** and the **GL-C** glasswashers are designed to produce sparkling clean glassware utilizing separate detergent, sanitizer and rinse aid chemical pumps. Standard features include upper and lower wash/rinse arms, wash tank heater, Poly Pro™ conveyor, splash curtains, double-walled construction, and storage space for three 1-gallon containers. The **GW-100** and the **GL-C** are constructed for extended life out of stainless steel.

