



GWX-200
Dual Door Pass Through
Glasswasher



NEW!
UNIQUE TWO DOOR
PASS THROUGH
OPERATION!

MODEL GWX-200

FEATURES:

- **ENERGY STAR® Approved**
- Stands 40" tall, with 11-1/4" clearance for glassware, and was designed to fit under any standard bar.
- At 30 racks per hour, this model has the capacity of 600 plus glasses per hour.
- 2-minute cycle-time, with water usage of 1.07 gallons of water per cycle.
- Uses 19-3/4"X19-3/4" standard racks.
- Stainless Steel construction for long term use and durability. Panels on the top and sides are a standard feature.
- Door safety switch system: This system automatically stops the operation, if either door is accidentally opened. This offers protection to both the serving staff and the back bar personnel.
- Chemical dispenser: The standard 3-product chemical dispensing system is mounted internally for space-saving in the underbar area.
- Revolving upper and lower Stainless Steel wash and rinse arms are standard. This system ensures maximum surface coverage of all types of glassware.
- Temperature gauge: Mounted on top and can be easily monitored.
- Sustainer heater for wash water temperature maintenance.
- Built-in Hot Water Assurance System guarantees hot water every cycle.
- Pump protection screen filters are HD Stainless Steel and can be easily removed and cleaned.



The GWX-200 can be loaded, unloaded or operated from either side of the bar.



Front Door loading by server staff made easy and efficient.



Back Door for bartender makes it easy to continue to serve customers while machine is producing clean sanitized glassware.



Front Door Controls are easy to read and simple to operate.



Back Door Control has a single "Start" switch making it simple and easy to operate.





GWX-200
Dual Door Pass Through
Glasswasher

WARNING: Plumbing connections must be made by a qualified service company who will comply with all available Federal, State, and Local Health, Plumbing and Safety codes.

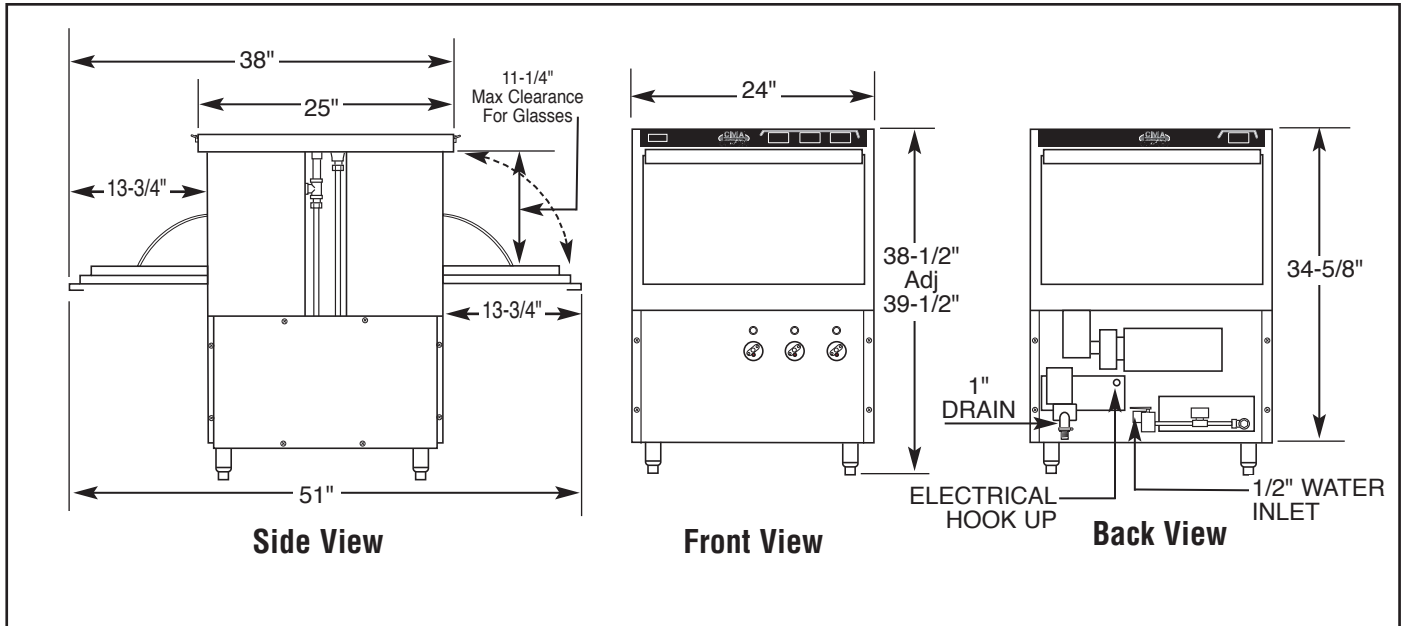

Specifications:

MODEL GWX-200	USA	METRIC	USA	METRIC
OPERATING CAPACITY				
RACKS PER HOUR	30 (600 PLUS GLASSES)	30 (600 PLUS GLASSES)		
OPERATING CYCLE				
WASH TIME-SEC	58	58		
RINSE TIME-SEC	32	32		
DWELL/TIME-SEC	30	30		
TOTAL CYCLE TIME	120	120		
WASH TANK CAPACITY	1.7 GAL.	(6.45 L)		
WASH PUMP CAPACITY	35 GPM	(132 LPM)		
MINIMUM TEMPERATURE REQUIRED				
WASH TEMP.	120°F	(50°C)		
WATER CONSUMPTION				
PER RACK	1.7 GAL.	(6.45 L)		
PER HOUR	40.8 GPH	(154.4 LPH)		
WATER INLET	1/2"	(1.27 cm)		
DRAIN	1"	(2.54cm)		
WASH PUMP MOTOR HP			1	1
DIMENSIONS				
DEPTH	25"	(63.5cm)		
WIDTH	24"	(61cm)		
HEIGHT	38-1/2"-39-1/2"	(97.8-100.3cm)		
MAXIMUM CLEARANCE FOR GLASSWARE	11-1/4"	(28.57cm)		
STANDARD DISHRACK DIMENSIONS	1	1	19-3/4"X19-3/4"	(50X50cm)
ELECTRICAL RATING			VOLTS	AMPS
			115	16
SHIPPING WEIGHT APPROXIMATE			244#	(110.6kg)

Summary Specifications: Model GWX-200 Dual Door Pass Through Glasswasher

The GWX-200 glasswasher is designed to produce sparkling clean glassware utilizing our unique Hot Water Assurance System. The GWX-200 is easy to use, fast and efficient, while conserving water, energy and chemicals. Built-in sustainer heater provides continuous 130°F hot water every cycle. The GWX-200 is constructed entirely of stainless steel and is equipped with an integrated chemical delivery system. The GWX-200 incorporates a pump purging system that improves results by eliminating soil and chemical carryover during rinse cycle.

