



CW1 NACHO CHIP WARMER (with forced air heating system)

CARTER-HOFFMANN



FOOD SERVICE EQUIPMENT
NACHO CHIP WARMERS

SPECIFICATIONS

Printed in U.S.A. E54 0808
Carter-Hoffmann is a registered trademark

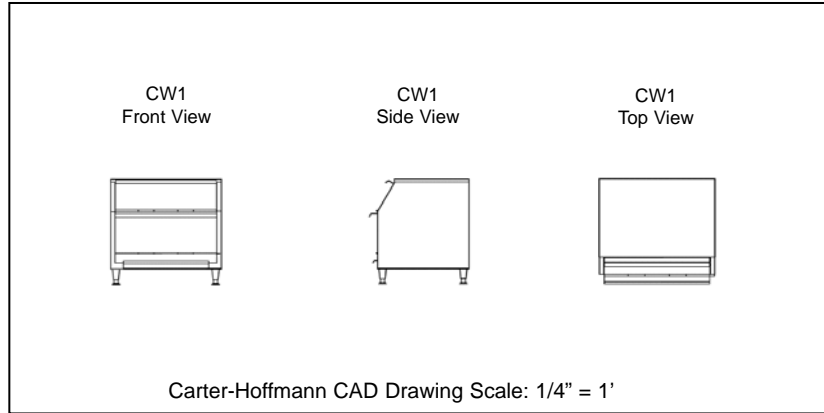

Model Number	Capacity Cubic Feet*	Overall Dimensions						Legs		Shipping Weight	
		Height**		Depth		Width		in	mm	lbs	kgs
		in	mm	in	mm	in	mm				
CW1	2.75	27 ¹ / ₄	692	25 ¹ / ₂	648	28 ³ / ₈	721	4	102	135	64

*Approximately 20 gallons of chips.

** Height includes 4" legs. Ordering optional casters or rubber feet will decrease height.

CONSTRUCTION... Completely welded cabinet construction with outer cabinet welded to cabinet liner.

CABINET MATERIAL... All stainless steel construction; 20 gauge polished exterior and 20 gauge interior.

INSULATION... High density fiberglass, full 1" thick continuous wrap-around type in bottom and sides.

DOORS... Single panel polished stainless steel. Product loading door features hinged front for easy loading. Loading door functions as chip ramp during loading. Serving door features two heavy-duty magnetic catches and functions as a platform for holding baskets in the open position.

HINGES... Integral and continuous rolled butt type hinges. Removable stainless steel full length hinge pin.

HANDLE... Bottom door and product loading door feature integrally formed, full width stainless steel handles.

BOTTOM CRUMB DRAWER... Integrated bottom drawer with drawer stop. Slides out for easy cleaning.

LEGS... 4" legs are standard. 1" rubber feet or 2" casters are optional.

CONTROLS... Internal mechanical thermostat. Factory pre-set temperature of 175°F (79°C). Adjustable with tools via access hole with grommet; located on rear of cabinet. On/off switch with power indicating light.

HEATING SYSTEM... Top mounted forced air heating system. Incoloy-sheathed heating elements, heavy duty fan motor.

ELECTRICAL CHARACTERISTICS... Operates on 120v, 1040 watts, 8.7 amps, 60 cycle, single phase. Six foot 3 wire rubber cord with 3 prong grounding plug. NEMA 5-15P.

PERFORMANCE... Capable of heating to 190° F (88° C). Preheat to 160° F (71° C) in approximately 20 minutes.

ACCESSORIES/OPTIONS...

- 240 volt electrical configuration
- 1/4" thick clear polycarbonate doors
- 1" rubber feet
- 2" casters

(Note: ULeph listing does not apply if 1" rubber feet or 2" caster options are chosen)

Specifications subject to change through product improvement & innovation.

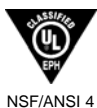

CARTER-HOFFMANN
1551 McCormick Ave., Mundelein, IL 60060
Tel (847) 362-5500 • (800) 323-9793 • Fax (847) 367-8981
www.carter-hoffmann.com

FEATURES & BENEFITS

1551 McCormick Avenue, Mundelein, Illinois 60060
Tel (847)362-5500 • (800) 323-9793 • Fax (847) 367-8981
www.carter-hoffmann.com



CW1 NACHO CHIP WARMER

Since 1947, Foodservice Equipment That Delivers!



EXCLUSIVE HEAT DUCT BAFFLING SYSTEM... Warm air is directed through duct and up through chips on the bottom. Assures uniform temperatures throughout cabinet for consistent holding of product.

HIGH PERFORMANCE CONVECTION HEATER... Heating system located in top of cabinet with blower for quick heat up and recovery and even heat distribution throughout cabinet.

STAINLESS STEEL CONSTRUCTION... All stainless steel for easy sanitation and long lasting clean appearance.

BOTTOM CRUMB DRAWER.. Catches broken chips and crumbs. Easily removed without tools for cleaning.

PATENTED FIRST-IN FIRST-OUT GRAVITY PRODUCT FEED... Facilitates constant product rotation to ensure freshness.

LARGE CHIP CAPACITY... Provides ample supply of product, even during peak hours. Approximatey 20 gallons. Interior chip ramp is removable for easy cleaning.

EXCLUSIVE DOOR DESIGN... Top door folds out and forms ramp to enable easy product fill. Serving door folds out and creates platform to rest baskets while serving.



NSF/ANSI 4