

MF

Built-In Remote Milk Or Beverage Dispensers

Project _____
Item _____
Quantity _____
CSI Section 11400
Approved _____
Date _____

Models

- MF-2020 Remote built-in dispenser with capacity for 378 half pint cartons
- MF-2821 Remote built-in dispenser with capacity for 126 half pint cartons
- MF-31 Remote built-in dispenser with capacity for 252 half pint cartons
- MF-44 Remote built-in dispenser with capacity for 378 half pint cartons
- MF-57 Remote built-in dispenser with capacity for 504 half pint cartons

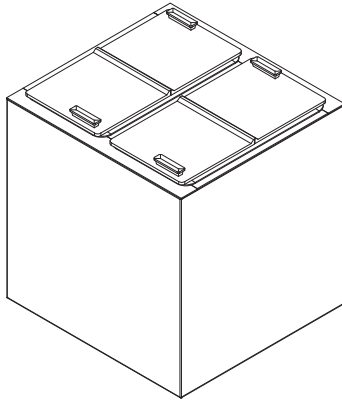

MF-31

Standard Features

- Exterior body and frame to be galvanized steel
- Units insulated with foamed in place environmentally friendly, Kyoto Protocol Compliant, Non ODP (Ozone Depletion Potential), Non GWP (Global Warming Potential) polyurethane
- 1" IPS drain
- Opening throat liner to be high impact plastic
- Self-leveling mechanisms shall be adjustable by adding and removing stainless steel extension springs located inside the elevator housing
- (6) Anodized aluminum divider trays per opening
- Dispenser platform carrier shall be stainless steel and removable for cleaning
- Insulated folding lid, stainless steel and high impact plastic
- An expansion valve and copper tubing connection to remote refrigeration system is provided
- One year parts and 90 day labor standard warranty

Options & Accessories

- Lid locking device
- Wire baskets (not available on MF-2020)
- Lexan[®] covers
- Special refrigerants (contact factory)*

* Inclusion of this option will alter electrical specifications of the unit

Specifications

The exterior bottom, sides and top edge shall be galvanized steel.

Inner liner shall be water tight and constructed of stainless steel with a 1.25" (3cm) I.P.S. drain. Opening(s) shall have throat liners constructed of high impact plastic. Unit to be insulated with foamed-in-place environmentally friendly, Kyoto Protocol Compliant, Non ODP (Ozone Depletion Potential), Non GWP (Global Warming Potential) polyurethane insulation with a non-conductive breaker strip.

Each opening shall have an insulated, stainless steel folding lid with high impact plastic liner, molded rubber edge and black plastic handles.

Each self-leveling mechanism shall be field adjustable by adding or removing stainless steel extension springs in the elevator housing inside the unit. The elevators shall be connected by removable platform carriers constructed of stainless steel.

Refrigeration system (to provided by others) shall use HFC-134a refrigerant. An expansion valve and copper tubing connection to the remote refrigeration system shall be provided.

NOTE: Temperature and pressure controls are not provided on remote models.

The following applies to models MF-2821, MF-31, MF-44 and MF-57 only. (6) anodized aluminum divider trays will be supplied per opening. See chart on back for milk storage capacity.

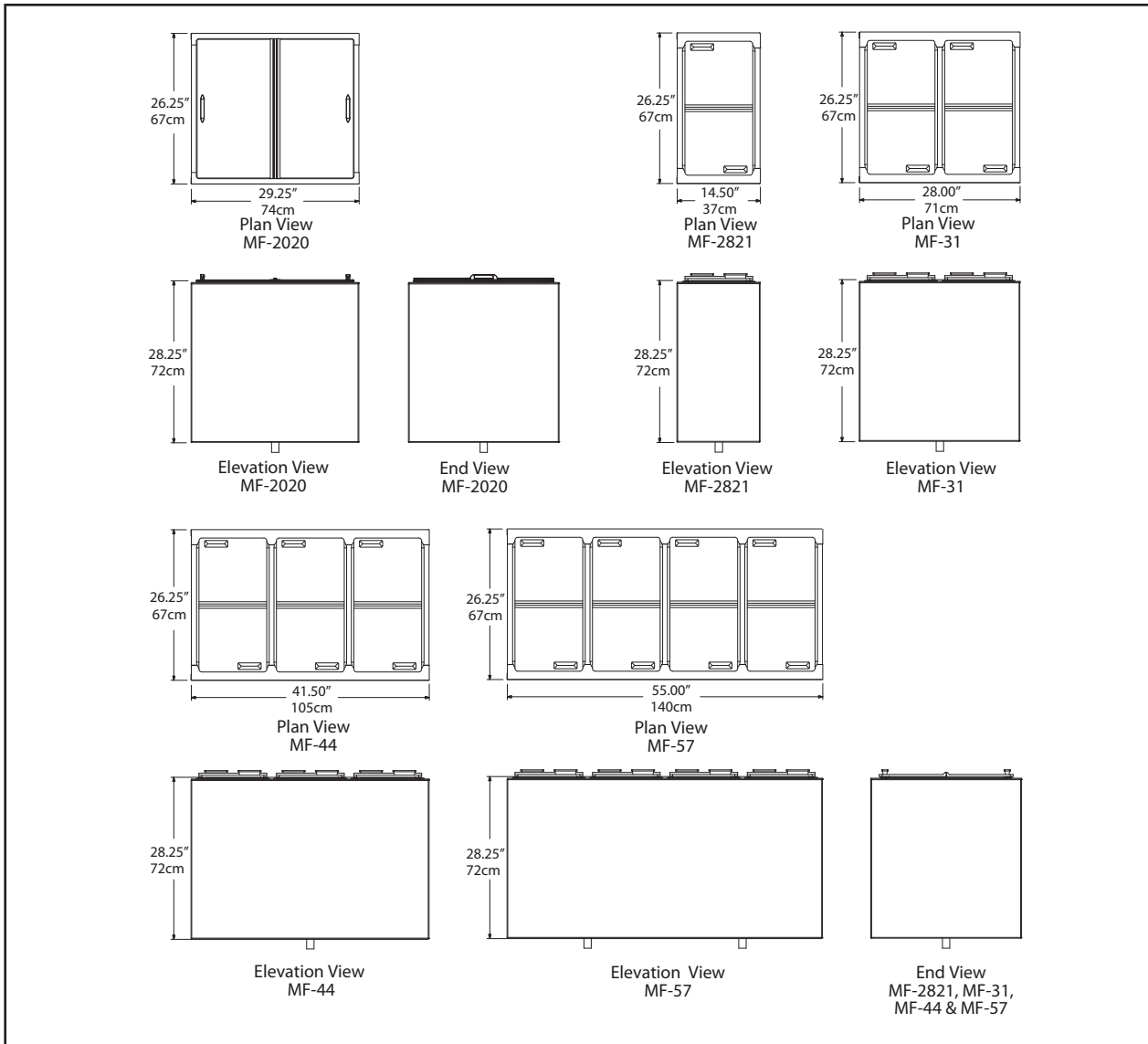

MF: Built-In Remote Milk Or Beverage Dispensers

Specifications

Model	Cutout Dimension (Length X Depth)	Half Pint Carton Capacity	Recommended H.P.	BTU Load	Evap Temp	Ship Weight
MF-2020	(1) 25.25" x 22.25" (1) 64cm x 57cm	378	1/4	300	30° F -1° C	240lbs 109kg
MF-2821	(1) 10.75 x 21.00" (1) 27cm x 53cm	126	1/4	260	30° F -1° C	197lbs 89kg
MF-31	(2) 10.75 x 21.00"* (2) 27cm x 53cm*	252	1/4	300	30° F -1° C	238lbs 108kg
MF-44	(3) 10.75 x 21.00"* (3) 27cm x 53cm	378	1/4	410	30° F -1° C	312lbs 142kg
MF-57	(4) 10.75 x 21.00"* (4) 27cm x 53cm*	504	1/4	520	29° F -2° C	335lbs 152kg

*Requires 2.75" (7cm) between each cutout

Delfield reserves the right to make changes to the design or specifications without prior notice.