

# Machine Stands

## Stainless Steel Mobile



Model 716

### Add Mobility To Kitchen Tasks

- Designed to securely hold many types of kitchen equipment.
- Lower shelf holds accessories and other supplies.
- Rugged stainless steel design features 18-gauge reinforced top supported by rigid 12-gauge angle legs.
- Transports equipment easily on 4" (102) swivel casters, 2 with brakes.
- NSF listed machine stands are available.
- Easy-to-clean and sanitize, simply wipe down or steam clean.

Spec. # \_\_\_\_\_

A/A # \_\_\_\_\_

### Specifications

Unit shall be of fully welded stainless steel construction. Top shall be of 18-gauge stainless steel with two reinforcements of .104 x 1" x 1" stainless steel angle. Under shelf shall be of 18-gauge stainless steel. Upright legs shall be of .104 x 1" x 1" stainless steel angle and shall be welded to top and under shelf at all points. Casters shall be 4" swivel with 3" stem mount. Two casters shall have brake.



Lakeside Manufacturing, Inc.

4900 West Electric Avenue • West Milwaukee, WI 53219 U.S.A.  
800-558-8565 • 414-902-6400 • Fax 414-902-6446 • www.eLakeside.com

# Machine Stands

## Stainless Steel Mobile

AIA #

Spec. #

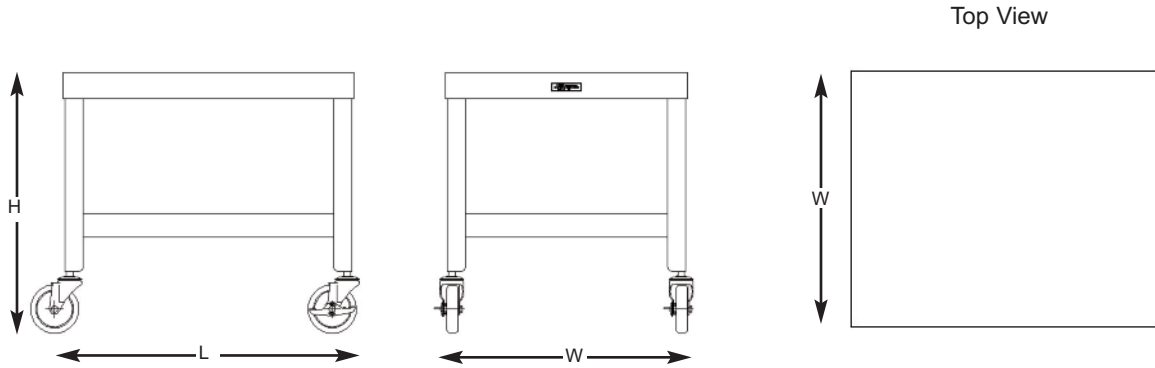

AutoCAD drawings available through KCL CADalog

### Dimensions

Model	NSF Listed Model	# of	Shelf Description		Overall Size			Case Weight	
			Size	Clearance	W	L	H	lb.	(kg.)
715	515	2	20" x 24" (508 x 610)	9-1/2" (241)	21-1/4" (540)	25-1/4" (641)	21-3/16" (538)	44	(20)
716	516	2	20" x 24" (508 x 610)	17-1/2" (445)	21-1/4" (540)	25-1/4" (641)	29-3/16" (741)	47	(21.3)
717	517	2	24" x 32" (610 x 813)	9-1/2" (241)	25-1/4" (641)	33-1/4" (845)	21-3/16" (538)	49	(22.2)
718	518	2	24" x 32" (610 x 813)	17-1/2" (445)	25-1/4" (641)	33-1/4" (845)	29-3/16" (741)	61	(27.7)

Measurements in ( ) denote metric millimeters, unless otherwise specified.

#### Option:

- Adjustable feet in place of casters



Lakeside Manufacturing, Inc.

4900 West Electric Avenue • West Milwaukee, WI 53219 U.S.A.  
800-558-8565 • 414-902-6400 • Fax 414-902-6446 • www.eLakeside.com