



Item No. \_\_\_\_\_

Project \_\_\_\_\_

Quantity \_\_\_\_\_

### MicroBakery™

### Model: MB- [AP/PT]



Model MB-PT shown

#### PAN CAPACITY GUIDE

Pan Type	Convection Oven	Staging	Proofer
13" X 18" Half-Sheet	5	4	12
12" X 20" Hotel*	5	4	12

\* 2-1/2" deep pans

#### SHORT/BID SPECIFICATION

Micro-Baking Center shall be a **LANG Manufacturing Model MB-** \_\_\_\_\_ stacked oven/staging cabinet/proofer unit with [AP=Accu-Plus or PT=Platinum] oven control package. Convection Oven to have 7.8-kW electric power input and five half-size pan capacity, with: heavy duty door; all stainless steel exterior and interior cooking compartment; powerful side mounted blower with two speed motor and pulse control; and five pan racks standard; plus a "lifetime" warranty on the door mechanism. Non-heated Staging Cabinet to have 4-pan capacity and the Proofing Cabinet shall be a Model PFMB 1.55-kW electric heated, single door unit, with: temperature and humidity controls; field reversible, full view tempered glass door with magnetic seal; 3" pan support spacing, interior air circulation system and water pan; plus all the features listed and options checked:

#### STANDARD PRODUCT WARRANTY

- One year, parts & labor
- Lifetime warranty on oven door mechanism

#### OVEN CONSTRUCTION FEATURES

- Heavy duty 430 Series stainless steel exterior, with attractive No. 4 finish
- Fully enclosed oven back
- Cooking compartment is 430 Series stainless steel
- 2" insulation on six sides of cooking compartment
- Heavy duty compartment door, with large double pane tempered glass window
- Powerful blower centered on side of compartment
- Chrome steel 9-position pan slides with five chrome plated wire racks provided

#### OVEN PERFORMANCE FEATURES

- 150° to 450°F operating temperature range
- Solid state temperature control accurate to 4°F
- Two speed fan with fan pulse capability
- Door interlock switch cuts power to fan
- Choice of two different control packages [See below]

#### OVEN CONTROL PACKAGE [Specify One]

- AccuPlus™ Control [-AP]**
  - Simple knob-set time and temperature controls
  - 1-hour timer with non-stop buzzer
  - Pulse-fan switch
  - HIGH-LOW speed fan switch
  - Power-ON switch
- Platinum Control [-PT]**
  - Solid state, icon driven, one-touch programmable controls
  - Up to 99 product programs, with multiple baking tiers
  - Time, temperature, heat loss and adjustable shelf compensation
  - Cook-n-Hold programming
  - 2-speed fan & variable-rate pulse-fan control
  - PC link programming
  - Power-ON switch

#### PROOFER CONSTRUCTION FEATURES

- All 304 stainless steel construction
- Tempered glass full view-merchandising type door
- Door is field-reversible, with magnetic seal and closure
- 6" X 12" removable water pan in compartment bottom

#### PROOFER PERFORMANCE FEATURES

- 80-150°F proofing temperature range
- 125-150°F holding temperature range
- Infinite-position humidity rate control, from "Low" to "High"
- Air circulation system ensures uniform proofing
- Only 1.55-kW [13 AMP] power required for proofer

#### MICROBAKERY CENTER FEATURES

- Compact bake center provides flexibility and saves space in small kitchens
- Staging Cabinet isolates oven heat and provides extra storage space
- Choice of: 6" swivel caster or 6" height adjustable legs std.



Sheet No. LSP-C14 (rev. 06/07)

**INSTALLATION REQUIREMENTS**

- (E) (E) Two electrical connections: [Convection Oven]: 208/240V, 1/ 3-Phase; or optional 480V, 3-phase electrical connection; [Proofer]: 120V, 1-Phase power connection, 6' power cord and plug provided; optional 208/240v
  - Installation under approved vent hood may be required. Consult local codes.
- [All connections from rear. See below]

**OVEN OPTIONS & ACCESSORIES**

- 480 Volt, 3-phase model
- 8' Power Cord Kit with NEMA L15-30P plug
- Factory recipe programming [Platinum/-PT models only]
- Reversible door [hinged left or right]
- Extra oven wire pan racks [5 provided as std.]

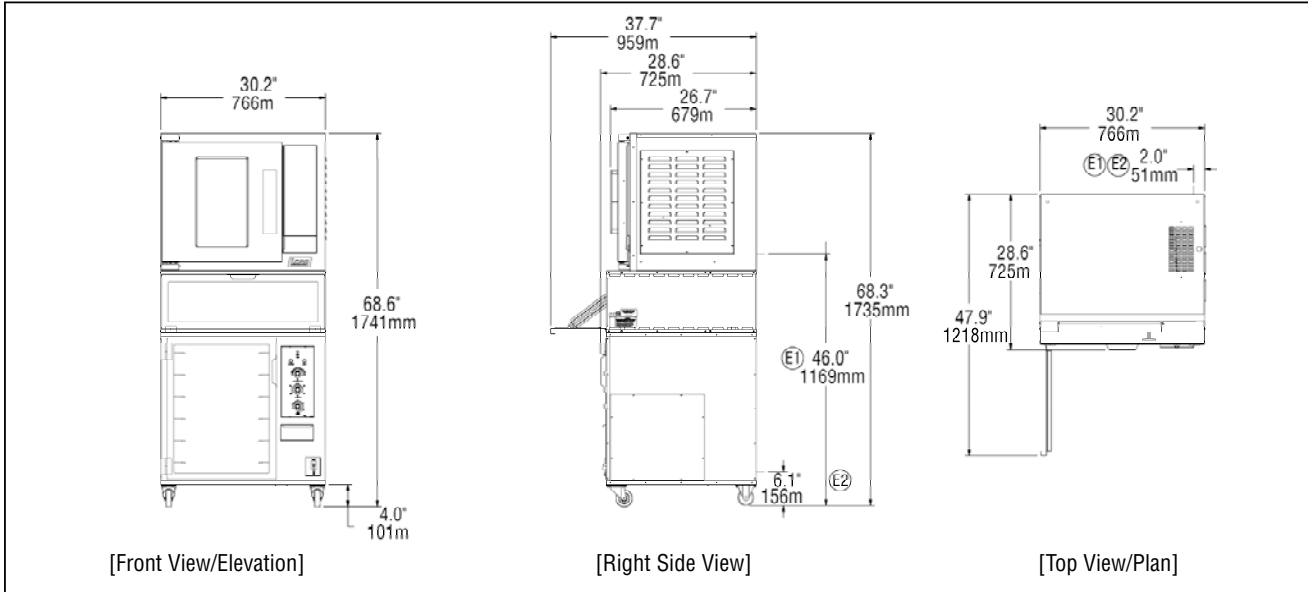

Model	Height x Width x Depth (with standard legs)	Clearance from combustible surface	Weight		Freight Class
			Actual	Shipping	
MB- <u>  </u>	68.6" x 30.2" x 28.6" 1741mm x 766mm x 725mm	Sides: 3 (77mm) Back: 3 (77mm) Floor: 3 (77mm)	435 lbs. 199 kg	485 lbs. 220 kg	85

Model MB- <u>  </u>	(E) Electrical Requirements			
	Voltage	Total kW	Phase	Amps/Line
OVEN	208V/60Hz	7.8	1	37.5
	240V/60Hz	7.8	1	32.5
	208V/60Hz	7.8	3	22.1
	240V/60Hz	7.8	3	19.1
PROOFER	115V/60Hz	1.8	1	15.7
	208V-240V	1.8	1	8.7

**CAD SYMBOLS & PRICING**



Due to continuous improvements, specifications subject to change without notice.



Sheet No. LSP-C14 (rev. 06/07)

**LANG MANUFACTURING - A DIVISION OF STAR MANUFACTURING INT'L, INC. • 10 SUNNEN DR. ST. LOUIS, MO 63143**  
**TOLL FREE: 800.264-7827 • FAX: 314-781-3636 • www.langworld.com**