



JOB:
ITEM:
QTY:



EQUIPMENT STAND

APPLICATION:

This all-purpose stand is perfect for microwaves, mixers, can openers, meat grinders, etc...

Removable aluminum or stainless steel top and optional under shelf lift off for easy cleaning and are fully supported by the all welded, heavy-duty frame.

Adjustable feet allow for quick stabilization and easy leveling. With a weight capacity of 1000# it is hard to find something this little stand won't hold.

MATERIAL:

Framework is constructed out of 1 1/2"x 1 1/2"x.070" wall tubing. Tops are constructed out of 16-gauge stainless steel and .080" aluminum sheet. These units come equipped with four NSF Certified adjustable feet.

GUARANTEE:

These units carry a **Lifetime Guarantee** against rust and corrosion and also carry a **Five-Year Guarantee** against workmanship and material defects.



Model #24ESS29US



Phone:800-255-0104
Fax: 877-877-7687
www.newageindustrial.com
sales@newageindustrial.com

New Age Industrial reserves the right to modify or make changes at any time without notice to materials and specifications.

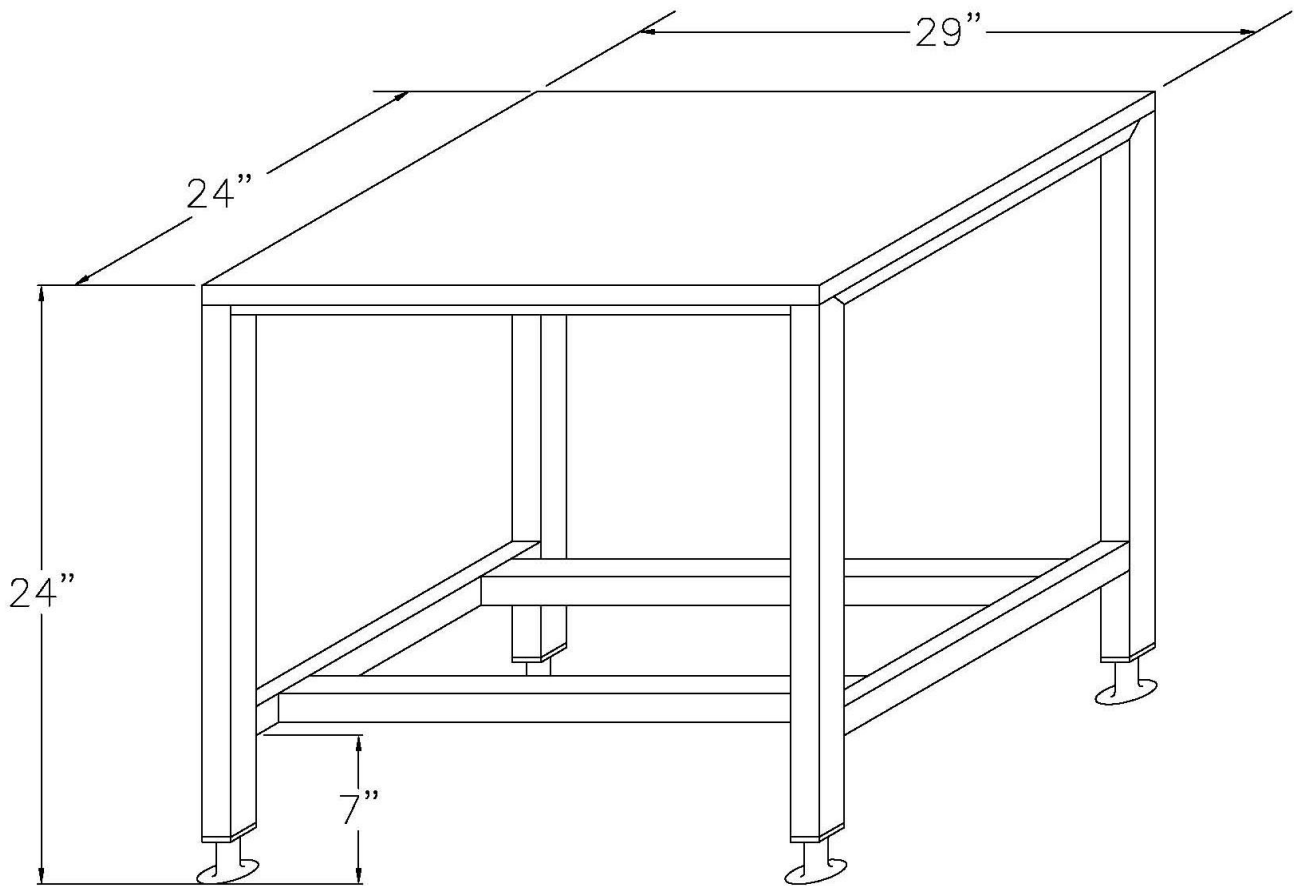

Model #24ESS29

Model No.	Size-W	Size-H	Size-D	Top Style
24ESS29	24"	24"	29"	Stainless
24ESA29	24"	24"	29"	Aluminum



Phone: 800-255-0104
 Fax: 877-877-7687
www.newageindustrial.com
sales@newageindustrial.com

New Age Industrial reserves the right to modify or make changes at any time without notice to materials and specifications.