

GRIDDLE STAND FREEZER (0°F)

Model: DL48GF

48" Griddle Stand Freezer

Stainless steel exterior and interior.

Designed to maintain NSF-7 temperatures in 100°F ambient.



Options and Accessories

(upcharge and lead times may apply)

| | |
|--|---|
| Doors in lieu of drawers | Adjustable legs |
| Flat top in lieu of marine edge | Remote models |
| 16-gauge stainless steel top (flat top only) | Digital thermometer |
| Condensing unit left or right | Cylinder locks |
| Automatic, electric condensate evaporator | Stainless steel pans |
| Stainless steel top extensions (flat or marine edge) | Special electrical requirements (consult factory) |

Consult factory for other model configurations, options and accessories.

Continental
Refrigerator

Toll-Free: 800-523-7138
Phone: 215-244-1400
Fax: 215-244-9579

539 Dunksferry Road
Bensalem, PA 19020
www.continentalrefrigerator.com

Project Name:

Model Specified:

Location:

Item No:

Quantity:

AIA #:

SIS #:

Standard Model Features

REFRIGERATION SYSTEM

- Performance-rated refrigeration system
- Environmentally-safe R-404A refrigerant
- Side-mounted, automatic, energy saving non-electric condensate evaporator
- Non-corrosive, plasticized fin evaporator coil
- Easily serviceable, front slide-out condensing unit

CABINET ARCHITECTURE

- High density, non-CFC polyurethane foamed-in-place insulation
- Easy glide, fully extendable drawers designed to hold 6" deep pans side-by-side
- One-piece, snap-in magnetic drawer gaskets
- Heavy-duty drawer track with built-in drawer safety clips
- Drawers designed to hold 250 lb. capacity
- 4" casters on support plates
- Stainless steel case back
- Reinforced stainless steel work top with drip guard marine edge

MODEL FEATURES

- Capillary dial thermometer
- Front breathing
- Automatic electric defrost

APPROVAL:

Model Specifications

DIMENSIONAL DATA

| | |
|---|-----------------|
| Net Capacity (cu. ft.) | 9.0 (255 cu l) |
| Width, Overall (in.) | 48 (1219 mm) |
| Depth, Overall (incl. handles) (in.) | 34 3/4 (883 mm) |
| Height, Overall (in.) (incl. 4" casters) | 26 3/8 (670 mm) |
| No. of Drawers | 2 |

REFRIGERANT DATA

| | |
|-----------------------------|------|
| Condensing Unit Size (H.P.) | 1/4 |
| Capacity (BTU/Hr)* | 1250 |

ELECTRICAL DATA

| | |
|-------------------------------------|---------------------|
| Voltage (int'l) | 115/60/1 (220/50/1) |
| Fans | 2 |
| Feed Wires (incl. ground) | 3 |
| Total Amps (int'l) | 5.7 (3.1) |
| Defrost Amps (int'l) | 4.3 (2.2) |
| 10 ft. Cord/Plug [attached] (int'l) | Yes (No) |

SHIPPING DATA

| | |
|-----------------------|--------------|
| Weight (lbs.) | 475 (215 kg) |
| Height - Crated (in.) | 44 (1118 mm) |
| Width - Crated (in.) | 64 (1626 mm) |
| Depth - Crated (in.) | 39 (991 mm) |

TOP WEIGHT CAPACITY

| | |
|---------------------------------|--------------|
| Max. Top Weight Capacity (lbs.) | 775 (352 kg) |
|---------------------------------|--------------|

* Rating @ -15°F evaporator, 90°F ambient
Figures in parentheses reflect metric equivalents rounded to the nearest whole unit.



Equipped with one NEMA-5-15P Plug
(varies by country)

Continental

Refrigerator

Toll-Free: 800-523-7138
Phone: 215-244-1400
Fax: 215-244-9579

539 Dunkserry Road
Bensalem, PA 19020
www.continentalrefrigerator.com

Due to our continued efforts in developing innovative products, specifications subject to change without notice.



MADE IN THE U.S.A.

© Copyright 2014. Continental Refrigerator.
A Division of National Refrigeration & Air Conditioning Products, Inc.

Model Plan Views

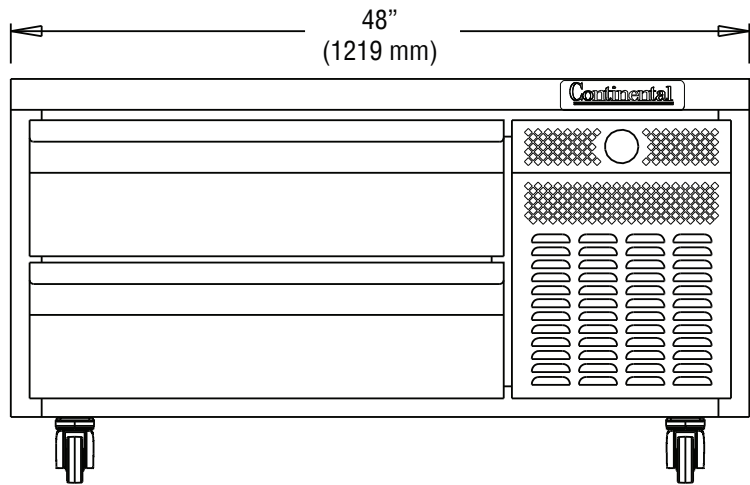

FRONT VIEW

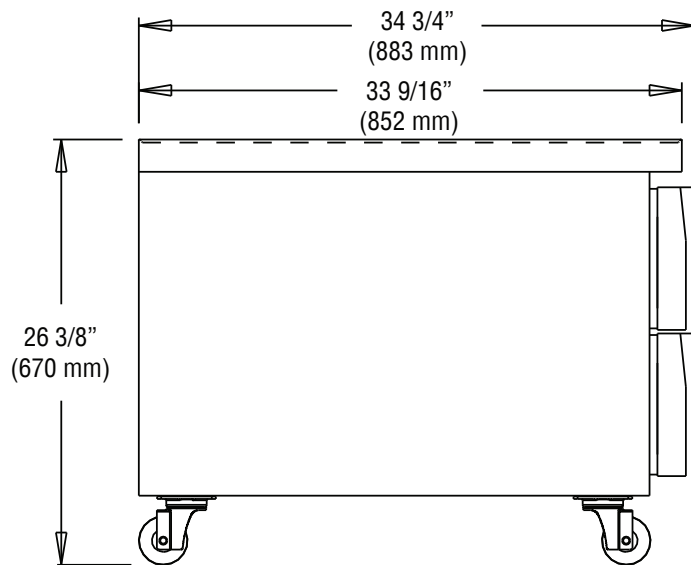

SIDE VIEW

Shown with (4) 12 x 20 x 6 pans (not furnished)

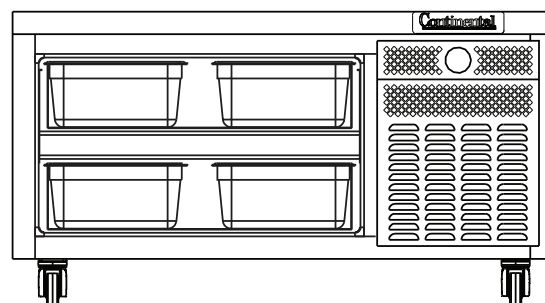

DRAWER PAN CONFIGURATION