



New **ULTRA-MAX® CHROME GAS GRIDDLES**
Models 824TSCHSA, 836TSCHSA, 848TSCHSA,
860TSCHSA & 872TSCHSA

Features/Benefits:

- ★ Ultra-Max® chrome griddles feature a hard chrome surface to provide superior cooking performance and even heat distribution. Highly polished smooth surface reflects heat inward reducing radiant heat, lowers energy cost up to 30% and keeps the kitchen cooler. The non-porous chrome surface eliminates food taste transfer and can be cleaned quickly, reducing labor cost.
- ★ *NEW* direct spark ignition for burners eliminate standing pilots. More efficient and no pilots to light.
- ★ Available in 24", 36", 48", 60" and 72" widths to meet your space and volume requirements.
- ★ *NEW* longer lasting, heavy-duty metal knobs.
- ★ All stainless steel construction and front panel.
- ★ *NEW* dual row porting 40,000 BTU steel burner every 12" of cooking surface provides superior cooking performance.
- ★ Heavy-duty all-weld body construction with stainless steel front, side panels, splash guard.
- ★ Stainless steel bull nose features cool to the touch technology providing a safe and comfortable work zone.
- ★ Ergonomically angled front panel providing easy access and viewing of controls.
- ★ Electronic flame monitoring with auto shutoff for added safety.
- ★ Spatula wide 3-1/2" front grease trough and grease chute for easier cleaning.
- ★ Large 6 quart stainless steel grease drawer.
- ★ Extra-heavy 4" adjustable legs to fit your countertop needs.
- ★ Floor model stands available for free standing unit. Optional casters available.
- ★ Cool-to-the-touch stainless steel bull nose front provides knob protection and comfortable work zone.



Model 836TSCHSA

Applications:

Ultra-Max chrome griddles provide high volume operations with superior performance, labor savings, energy savings and maximum results for a variety of menu items.

Construction:

Ultra-Max chrome griddles feature 1" thick highly polished steel plate with chromium surface, 5" tapered stainless steel splash guard and 3-1/2" wide front access grease trough with 6 quart grease drawer capacity. Models 860TSCHSA and 872TSCHSA house two 6 quart grease drawers. Includes a 40,000 BTU aluminized steel burner every 12" of width controlled by snap-action control valve (110V) 3/4" N.P.T. male gas connection with convertible pressure regulator and 4" adjustable legs. Units are supplied with 6' cord with NEMA 5-15 plug.

New **Warranty:**

Ultra-Max chrome griddles are covered by Star's **three year** parts and labor warranty. In addition, the Ultra-Max chrome surface is warranted for 5 years!





New **ULTRA-MAX® CHROME GAS GRIDDLES**
Models 824TSCHSA, 836TSCHSA, 848TSCHSA,
860TSCHSA & 72TSCHSA

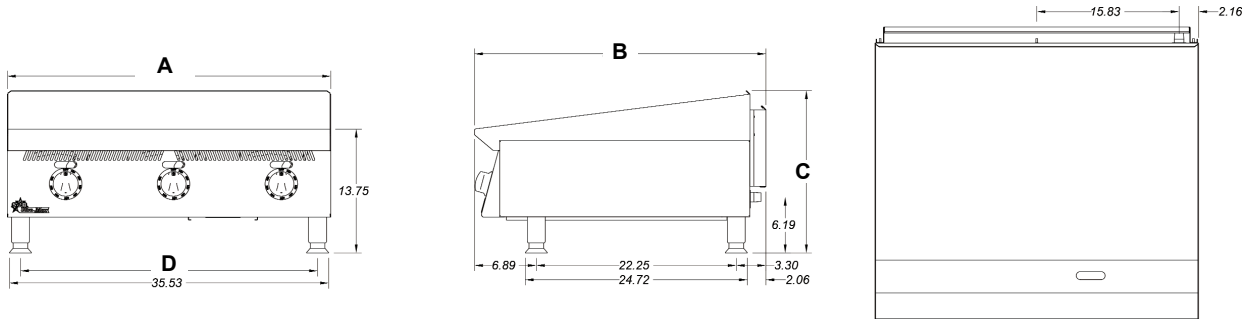

Specifications

Model No.	Dimensions				No. Controls	BTU	Grid Area	Plate Thickness	Approximate Weight	
	(A) Width Inches	(B) Depth Inches	(C) Height Inches	(D) Leg Width Inches					Installed	Shipping
824TSCHSA	24" (61.0 cm)	32-3/8" (82.2 cm)	18" (45.7 cm)	21-1/16" (53.5)	2	80,000	573 sq. in. (3,697sq cm)	1" (2.54 cm)	222 lbs. (100.6 kg)	305 lbs. (137.3 kg)
836TSCHSA	36" (91.4 cm)	32-3/8" (82.2 cm)	18" (45.7 cm)	33-1/16" (84)	3	120,000	860 sq. in. (5,545 sq cm)	1" (2.54 cm)	333 lbs. (150.9 kg)	409 lbs. (184.1 kg)
848TSCHSA	48" (121.9cm)	32-3/8" (82.2 cm)	18" (45.7 cm)	45-1/16" (114.5)	4	160,000	1146 sq. in. (7,394 sq cm)	1" (2.54 cm)	444 lbs. (201.2 kg)	524 lbs. (235.8 kg)
860TSCHSA	60" (152.4 cm)	32-3/8" (82.2 cm)	18" (45.7 cm)	57-1/16" (144.9)	5	200,000	1433 sq. in. (9,242 sq cm)	1" (2.54 cm)	555 lbs. (251.5 kg)	688 lbs. (309.6 kg)
872TSCHSA	72" (182.9 cm)	32-3/8" (82.2 cm)	18" (45.7 cm)	69-1/16" (175.4)	6	240,000	1719 sq. in. (11,091 sq cm)	1" (2.54 cm)	666 lbs. (301.8 kg)	794 lbs. (357.3 kg)

Typical Specifications

Ultra-Max Chrome Gas griddles are constructed of stainless steel, valve knobs are protected by a stainless steel bull nose front. Griddle plate is a 1" (2.54 cm) thick highly polished chrome plated steel plate with 5" (7.6 cm) high tapered wrap-around stainless steel splash guard. Unit has 3-1/2" (8.3 cm) wide front grease trough with grease chute and a 6 qt. (5.68 L) capacity stainless steel grease drawer. Models 860TSCHSA and 872TSCHSA house two each 6 quart grease drawers. Units are equipped with a 40,000 BTU aluminized steel burner for every 12" (30.5 cm) of width and are controlled by a snap action control valve (110V) with an electric spark ignition and 3/4" N.P.T. male gas connection with a convertible pressure regulator. Griddles are supplied with 4" (10.2 cm) high stainless steel legs that have a 1-5/8" (4.5 cm) adjustment. Supplied with 6' cord and NEMA 5-15 plug. Units are approved for installation within 6" (15.2 cm) of combustible surfaces and are CULus Classified and UL classified to NSF Standard 4 Sanitation. Printed in the U.S.A.

Due to periodic changes in designs, methods, procedures, policies and regulations, the specifications contained in this sheet are subject to change without notice. While Star Manufacturing exercises good faith efforts to provide information that is accurate, we are not responsible for errors or omissions in information provided or conclusions reached as a result of using the specifications. By using the information provided, the user assumes all risks in connection with such use.

Star Manufacturing - 10 Sunnen Drive - P.O. Box 430129 - St. Louis, MO 63143-3800
 Phone: (314) 678-6303 - FAX: (314) 781-5445 - www.star-mfg.com