

**REFRIGERATOR MANUFACTURER**  
**Turbo air**  
 more durable, convenient, beautiful

1250 Victoria St  
 Carson, CA 90746  
 Tel. 310-900-1000  
 Fax. 310-900-1077  
[www.turboairinc.com](http://www.turboairinc.com)

Project :	
Model # :	
Item # :	Qty :
Available W/H :	
Approval :	

# Solid Door Refrigerator

*Reach-In Bottom Mounts  
Super Deluxe Series*

**Model : TSR-49SD**

## FEATURES / BENEFITS

- **DIGITAL TEMPERATURE CONTROL SYSTEM**  
 Provides precise and constant temperature. This level of precision allows food products to remain fresh over an extended period of time.
- **HIGH-TECH MONITOR**  
 The unit will beep if the door has been opened for more than 30 seconds. The monitor digitally displays the present temperature and current status of the refrigerator. You can easily change the temperature by adjusting the thermostat.
- **STAINLESS STEEL CABINET CONSTRUCTION**  
 The Turbo Air Super Deluxe model boasts a stainless steel interior and exterior (galvanized steel top, bottom and back). It guarantees the utmost in cleanliness and long product life. Unlike other companies' products, the sharp corners and edges have been rounded to reduce the risk of injury. The Super Deluxe can add a touch of style to the most refined setting.
- **STURDY, CLEAN STAINLESS SHELVING**  
 Shelves are the most important part of cleanliness as they come in direct contact with food. After a while, PVC coated wire shelves may peel, rust and lead to unsanitary conditions. Only the Turbo Air Super Deluxe series uniquely provides stainless shelving.
- **EFFICIENT REFRIGERATION SYSTEM**  
 Turbo Air's solid door refrigerators are designed with oversized and balanced (CFC Free R-134A) refrigeration systems. These include efficient evaporators and condensers for faster cooling and greater efficiency.
- **AUTOMATIC EVAPORATOR FAN MOTOR DELAYS**  
 Through stopping the evaporator fan when the refrigerator door opens, the circulation of hot, moist air into the refrigerator is prevented. This increases energy efficiency and lengthens the life of the compressor.
- **HIGH-DENSITY POLYURETHANE INSULATION**  
 The entire cabinet structure and solid doors are foamed-in-place using high density, CFC free polyurethane insulation.
- **ERGONOMICALLY DESIGNED DOORS**  
 Customers' fatigue fades away with easy grip handles and doors that open effortlessly. Self-closing and stay open door features make this the ultimate choice in customer convenience.
- **MAGNETIC DOOR GASKETS**  
 Magnetic door gaskets are of one piece construction, removable without tools for ease of cleaning and replacement.
- **BOTTOM MOUNT COMPRESSOR UNITS**  
 Turbo Air's bottom mount compressor allows easier access for service and extra storage space above. In addition, the lower area provides a cooler and less greasy operating environment which results in reduced compressor running time.

**EXCEPTIONAL 3 YEAR  
PARTS & LABOR WARRANTY**



**REFRIGERATOR HOLDS 33°F ~ 38°F  
FOR THE BEST IN FOOD PRESERVATION**



Model	Swing Door	CU./FT.	#of Shelves	HP	AMPS	Crated Weight (lbs.)	L x D x H* (inches)
TSR-49SD	2	49	6	1/3	9.2	427	543/8 x 303/8 x 781/4

# Solid Door Refrigerator

Reach-In Bottom Mounts  
Super Deluxe Series

## Model : TSR-49SD

ELECTRICAL DATA	
Voltage	115/60/1
Plug Type	Ⓜ NEMA-5-15P
Full Load Amperes	9.2
Compressor HP	1/3
Feed Wires with Ground	3
Cord Length ft.	9
Refrigerant	R-134A
DIMENSIONAL DATA	
# of Doors	2
# of Racks Accepted	2
Net Capacity cu. ft.	49
Ext. Length Overall in.	54 <sup>3</sup> / <sub>8</sub> (1382mm)
Ext. Depth Overall in.	30 <sup>3</sup> / <sub>8</sub> (770mm)
Ext. Height Overall in.*	78 <sup>1</sup> / <sub>4</sub> (1987mm)
Int. Length Overall in.	50 <sup>1</sup> / <sub>2</sub> (1283mm)
Int. Depth Overall in.	24 <sup>3</sup> / <sub>4</sub> (630mm)
Int. Height Overall in.	60 <sup>3</sup> / <sub>8</sub> (1534mm)
Gross Weight lbs.	427
# of Shelves	6
Shelf Size (LxD) in.	24 <sup>3</sup> / <sub>8</sub> x 23 <sup>1</sup> / <sub>4</sub>

Design and specifications subject to change without notice.

Actual shipping weight may differ due to extra packing materials for product protection.

\* Height does not include 5" caster height or 6" optional legs.

- **WARRANTY :** Exceptional 3 Year Parts and Labor Warranty  
Additional 2 Year Warranty on Compressor
- SAFETY SHIELDED INCANDESCENT INTERIOR LIGHTING
- DOOR LOCKS STANDARD ■ SELF-CONTAINED SYSTEM
- POSITIVE SEAL SELF-CLOSING DOORS
- EASY REPLACEABLE ONE PIECE MAGNETIC DOOR GASKETS
- STANDARD 4" SWIVEL CASTERS WITH LOCKS ON THE FRONT SET
- SOLID AND STURDY GRILLE DESIGN
- TRAY RACK AVAILABLE (OPTIONAL)
- REMOTE CABINETS AND CONDENSING UNITS AVAILABLE
- **OPTIONAL ACCESSORIES :**
  - 5" Diameter swivel casters
  - 6" Standard legs
  - Additional stainless steel shelves
  - Additional PE coated wire shelves
  - Half door bun tray racks. Each holds up to seven 18"Lx26"D sheet pans (sold separately)
  - Full door bun tray racks. Each holds up to fifteen 18"Lx26"D sheet pans (sold separately)
  - Remote cabinets and condensing units  
(Extra lead times may apply)

Ver.201301

## PLAN VIEW

(unit : inch)

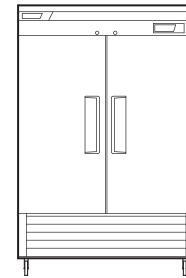

FRONT VIEW

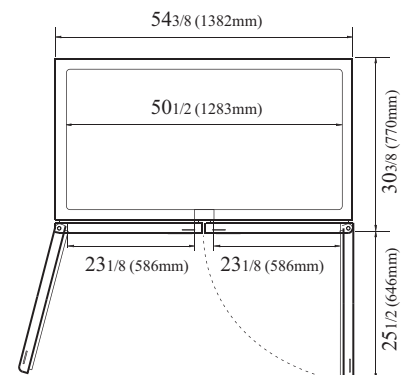

PLAN VIEW

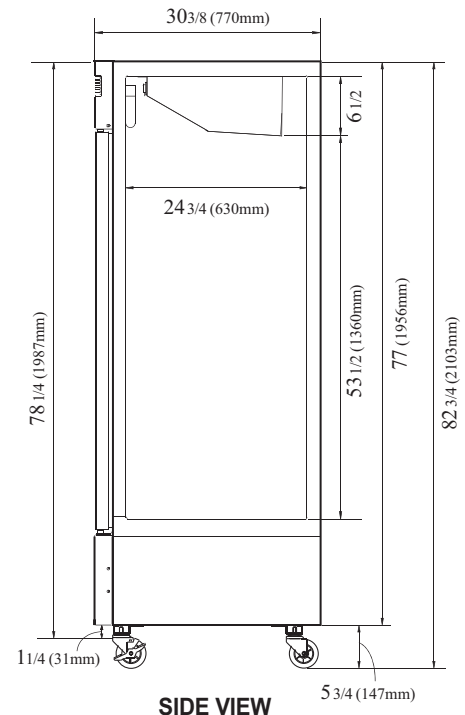

SIDE VIEW



ENERGY STAR®  
Qualified

- Turbo Air : 800-627-0032 ■ GK : 800-500-3519
- Warranty : 800-381-7770 ■ AC : 888-900-1002

REFRIGERATOR MANUFACTURER  
**Turbo air**

**GERMAN KNIFE**

**RADIANCE**

**GREEN WORLD**

AIR CONDITIONER MANUFACTURER  
**Turbo air**