

TURBO AIR REFRIGERATOR MANUFACTURER
Turbo air
 more durable, convenient, beautiful

1250 Victoria St
 Carson, CA 90746
 Tel. 310-900-1000
 Fax. 310-900-1077
www.turboairinc.com

| | |
|-----------------|-------|
| Project : | |
| Model # : | |
| Item # : | Qty : |
| Available W/H : | |
| Approval : | |

Undercounter Refrigerator-Drawers

Undercounters
 Super Deluxe Series

Model : TUR-60SD-D2

**EXCEPTIONAL 3 YEAR
 PARTS & LABOR WARRANTY**



- Drawer pans not included.

FEATURES / BENEFITS

■ **STAINLESS STEEL CABINET CONSTRUCTION**

The Turbo Air Super Deluxe model boasts a stainless steel interior and exterior (galvanized steel back & bottom). It guarantees the utmost in cleanliness and long product life. The Super Deluxe can add a touch of style to the most refined setting.

■ **DURABLE STAINLESS STEEL DRAWERS**

Drawers are easy to clean and assemble.

■ **HOT GAS CONDENSATE SYSTEM**

Through Turbo Air's creative innovation, the condensate system surfaces have been specially treated to resist corrosion. This not only increases efficiency without the risk of refrigerant leakage from corrosion, but also prevents the overflow of condensate water.

■ **EFFICIENT REFRIGERATION SYSTEM**

Turbo Air's solid door refrigerators are designed with oversized and balanced (CFC Free R-134A) refrigeration systems. These include efficient evaporators and condensers for faster cooling and greater efficiency.

■ **HIGH-DENSITY POLYURETHANE INSULATION**

The entire cabinet structure and solid doors are foamed-in-place using high density, CFC free polyurethane insulation.

■ **ERGONOMICALLY DESIGNED DOORS & DRAWERS**

Customers' fatigue fades away with easy door grip and drawers that open effortlessly. These features along with self-closing doors make this the ultimate choice in customer convenience. ABS sheet door liners resist water condensation with thermal efficiency.

■ **MAGNETIC DOOR GASKETS**

Magnetic door and drawer gaskets are of one piece construction, removable without tools for ease of cleaning and replacement.

■ **REFRIGERATOR HOLDS 33°F ~ 38°F FOR THE BEST IN FOOD PRESERVATION**



| Model | Swing Door | CU./FT. | #of Shelves | HP | AMPS | Crated Weight (lbs.) | L x D* x H† (inches) |
|--------------------|------------|-----------|-------------|------------|------------|----------------------|-----------------------------|
| TUR-60SD-D2 | 1 | 16 | 1 | 1/3 | 8.9 | 288 | 60 1/4 x 30 x 30 5/8 |

Model : TUR-60SD-D2

| ELECTRICAL DATA | |
|--------------------------|--|
| Voltage | 115/60/1 |
| Plug Type |  NEMA-5-15P |
| Full Load Amperes | 8.9 |
| Compressor HP | 1/3 |
| Cord Length ft. | 9 |
| Refrigerant | R-134A |
| DIMENSIONAL DATA | |
| Net Capacity cu. ft. | 16 |
| Ext. Length Overall in. | 60 1/4 (1530mm) |
| Ext. Depth Overall in.* | 30 (762mm) |
| Ext. Height Overall in.† | 30 5/8 (777mm) |
| # of Doors | 1 |
| # of Shelves | 1 |
| Gross Weight lbs. | 288 |
| Net Weight lbs. | 250 |

Design and specifications subject to change without notice.
Actual shipping weight may differ due to extra packing materials for product protection.
* Depth does not include 1" for rear spacers. † Height does not include 5-7/8" for caster height.

■ **WARRANTY :** Exceptional 3 Year Parts and Labor Warranty
Additional 2 Year Warranty on Compressor

- SELF-CONTAINED SYSTEM
- 4" SWIVEL CASTERS
- 2.5" DIA. CASTERS AVAILABLE (OPTIONAL)
- LEGS AVAILABLE FOR ALL MODELS (OPTIONAL)

■ **OPTIONAL ACCESSORIES :**

- 2.5" Diameter casters
- 5" Diameter casters
- 6" ABS plastic legs
- Stainless steel double over-shelf

PLAN VIEW

(unit : inch)

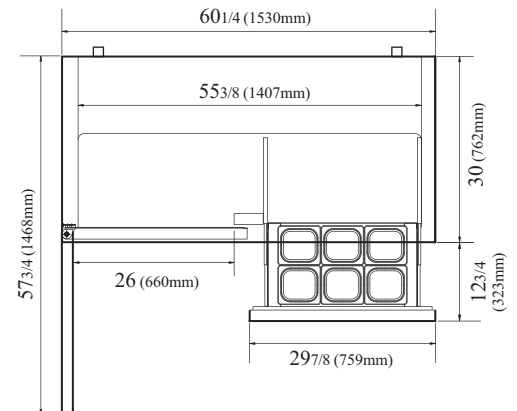

PLAN VIEW

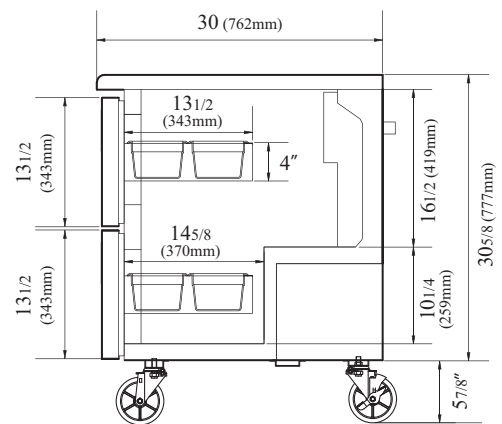

SIDE VIEW

Ver.201301



- Turbo Air : 800-627-0032
- GK : 800-500-3519
- Warranty : 800-381-7770
- AC : 888-900-1002