

Project: \_\_\_\_\_ Location: \_\_\_\_\_ Item #: \_\_\_\_\_ Quantity: \_\_\_\_\_

## Standard Features

- c-CSA-us and NSF certified.
- All Stainless Steel Exterior.
- Pan is 10 gauge Stainless Steel with a #4 finish Exterior, Polished Interior.
- Even Heat Distribution with 3/8" thick Stainless Steel Clad Plate.
- Heavy-Duty welded Frame.
- Can be mounted to a 30" wide Stainless Steel stand.

## Optional Features

- Etched gallon markings (ACGMS-16).
- Etched litre markings (ACLMS-16).
- Correctional Package.

## Electrical Options

- 208 VAC, 1 phase, 50/60 Hz.
- 208 VAC, 3 phase, 50/60 Hz.
- 220 VAC, 1 phase, 50/60 Hz.
- 220 VAC, 3 phase, 50/60 Hz.
- 240 VAC, 1 phase, 50/60 Hz.
- 240 VAC, 3 phase, 50/60 Hz.
- 380/220 VAC, 3 phase, 50/60 Hz.
- 415/240 VAC, 3 phase, 50/60 Hz.
- 480 VAC, 3 phase, 50/60 Hz.

## Short Spec

Counter top tilting skillet shall be AccuTemp's ECTRS-16 series, electrically heated counter tilting skillet. The skillet shall be constructed of all stainless steel. The pan sides shall slope outward to facilitate access to the cooking surface. Pan shall be fitted with side pivots mounted in sealed stainless steel clad consoles mounted on a 10 gauge stainless steel base with #4 finish. Pan shall be fitted with a stainless steel tilt handle with heat resistant knob for tilting the pan forward for complete removal of contents with provisions for mounting on left or right sides. A tilt interlock shall prevent inadvertent tilting of the pan.

Controls shall be integrally mounted and shall include a power switch, pilot light, thermostat, and high temperature cut-off.

The skillet shall operate in a temperature range of 160°F to 445°F (70°C to 230°C).

The skillet can be mounted on a 30" (762 mm) wide stainless steel stand.

## Other Approvals



ACECTRS-16 Model Shown

## Accessories

- Steam Pan Insert (ACSPI-16).
- One piece lift-off Stainless Steel cover (ACSC-16).
- 21" high floor stand c/w sliding shelf (ACS-30).
- 18" high floor stand c/w sliding drain pan and stationary drain (ACSD-30-16).
- 12" Single Pantry Faucet with swing spout (ACSF-12).
- 12" Double pantry faucet with swing spout (ACDF-12).
- Single pantry Kettle Filler, with Bracket (ACSP-KF).
- Double pantry Kettle Filler, with Bracket (ACDP-KF).

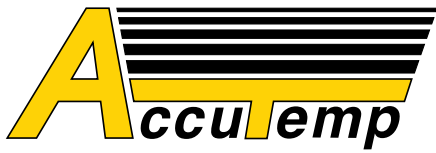

# ELECTRIC COUNTER TILTING ROUND SKILLET

16 Gallon Capacity—Electric Heated,  
Manual Tilt, Round Pan, Electric Skillet

Tilt Skillet Model "ACECTRS-16" Specifications								
Model #	kW	Phase	AMPS PER LINE					
			208V	220V	240V	380V	415V	480V
ACECTRS-16	7.5	1	36.0	34.1	31.3	N/A	N/A	N/A
		3	20.8	19.7	18.1	11.4	10.4	9.0

Model #	DIMENSIONS									
	Shipping Weight	Capacity	UNITS	Unit Width OD	Pan ID	Pan Height	Height with ACSD-30 stand	Height with Handle	Height with Handle and ACSD-30 stand	ACSD-30 stand Height
ACECTRS-16	220 LBS. [100 KG]	16 gallons 60 litres	inches	29.25	26.0	8.75	41.25	38.75	57.25	18.5
			mm	743	660	222	1049	984	1454	470

**Notes:**

1. Electrical connection to be specified on the data plate.
2. Drain: 1 1/2" - 1 1/2" NPT.
3. Hot & Cold Water: 3/8" OD tubing to Faucet (optional).

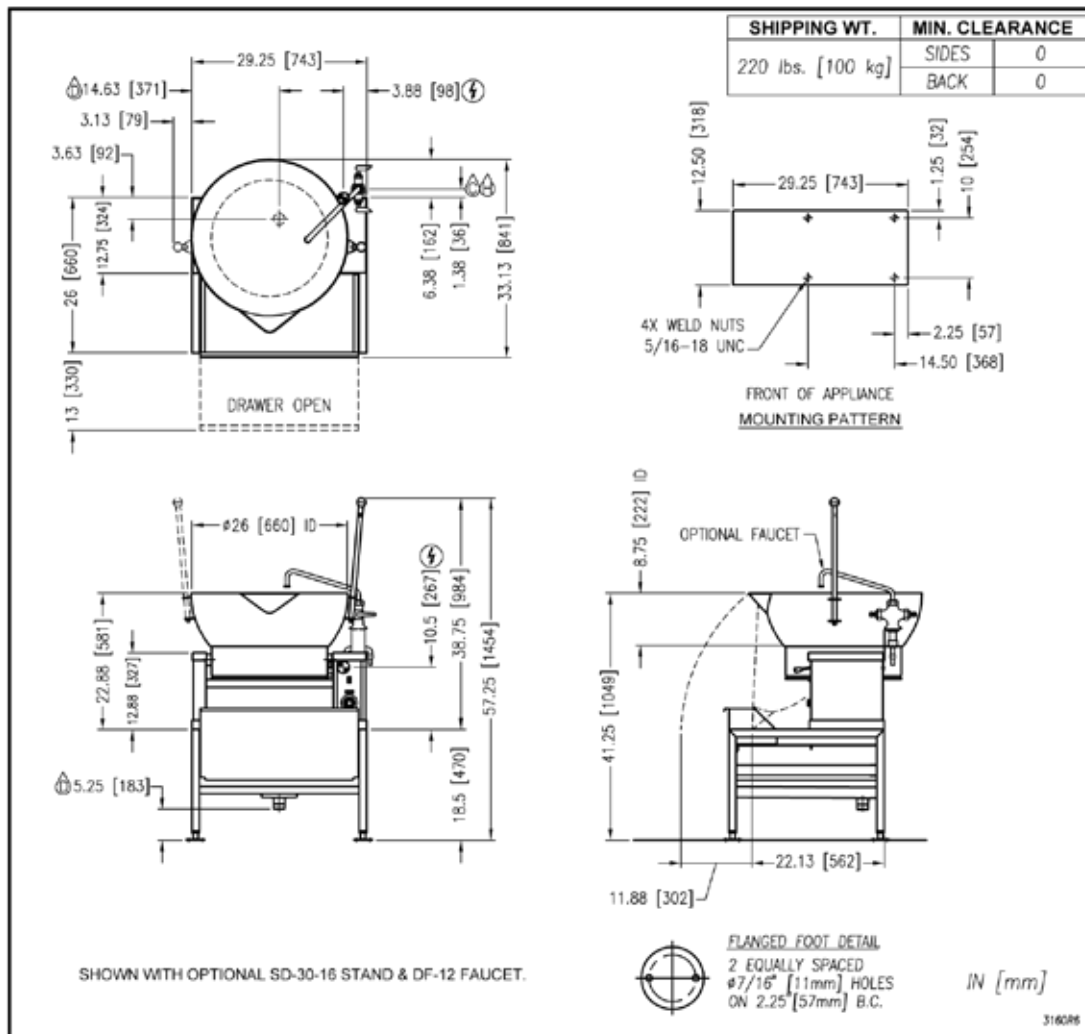

MM6205-1105

AccuTemp Products, Inc.

8415 North Clinton Park • Fort Wayne, IN 46825 • 800-210-5907 • 260-493-0415 • Fax 260-493-0318 • accutemp.net