

Project: _____ Location: _____ Item #: _____ Quantity: _____

Standard Features

- Natural Gas only.
- AGA/CGA and NSF certified.
- All Stainless Steel Exterior.
- Pan is 10 gauge Stainless Steel with a #4 finish Exterior, Polished Interior.
- Even Heat Distribution with 3/8" thick Stainless Steel Clad Plate.
- Can be mounted to a 30" wide Stainless Steel stand.

Optional Features

- 220 VAC, 1 Phase, 50/60 Hz.
- Etched gallon markings (ACGMS-30, ACGMS-40).
- Etched litre markings (ACLMS-30, ACLMS-40).
- Correctional Package.

Electrical Options

- 115 VAC, 1 Phase, 50/60 Hz. 30,000 BTU.
- 220 VAC, 1 Phase, 50/60 Hz.

Pan Capacity

Pan Size	Btu	Gallon	Litre
26" Inside Dia.	30,000	16	60

Short Spec

Round counter tilt skillet shall be AccuTemp's ACGTRS-16 series natural gas fired counter tilting skillet. The skillet shall be constructed stainless steel with a #4 exterior finish and a polished interior. The pan sides shall slope outward to facilitate access to the cooking surface. Cooking surface shall be 3/8" (9.5250 mm) thick stainless steel clad plate, ensuring even heat transfer over entire cooking surface. Pan shall be fitted with side pivots mounted in sealed stainless steel clad consoles mounted on a 10 gauge stainless steel base with #4 finish. Pan shall be fitted with a stainless steel tilt handle with heat proof knob for tilting the pan forward for complete removal of contents with provisions for mounting on left or right sides. A tilt interlock shall prevent inadvertent tilting of the pan.

Controls shall be integrally mounted and shall include a power switch, solid state thermostat, temperature pilot light, electronic ignition, ignition light, and a high limit temperature cut-off. Burner turns off automatically when pan is tilted. The skillet shall operate in a temperature range of 100°F to 450°F (38°C to 232°C).

The skillet can be mounted on a 30" (762 mm) wide stainless steel stand with sliding drain pan and stationary drain.

Other Approvals



ACGTRS-16 Model Shown
with Optional Stand

Accessories

- Steam Pan Insert (ACSPI-16).
- One piece lift-off Stainless Steel cover (ACSC-16).
- 18" high floor stand c/w sliding drain pan and stationary drain (ACSD-30-16).
- 12" Single Pantry Faucet with swing spout (ACSF-12).
- 12" Double pantry faucet with swing spout (ACDF-12).
- Single pantry Kettle Filler, with Bracket (ACSP-KF).
- Double pantry Kettle Filler, with Bracket (ACDP-KF).

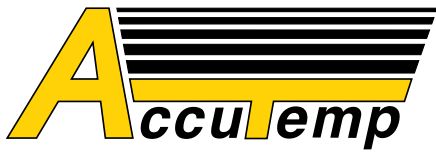

GAS COUNTER TILTING ROUND SKILLET

16 GALLON CAPACITY—GAS FIRED,
MANUAL TILT, ROUND PAN, ELECTRONIC IGNITION

Tilt Skillet Model "ACGCTRS" Specifications					
GAS SUPPLY					
Model #	BTU/HR.	KW/HR	SUPPLY PIPE PRESSURE (W.C.)		MIN CLEARANCE*
ACGCTRS-16	30,000	8.8	Natural 7"-14" (178-355mm)		SIDES 3 [76] BACK 6 [152]

DIMENSIONS										
Model #	Shipping Weight	Capacity	UNITS	Unit Width OD	Pan ID	Pan Height	Height with ACSD-30G stand	Height with Handle	Height with Handle and ACSD-30G stand	ACSD-30G Stand Height
ACGCTRS-16	285 LBS. [129 KG]	16 gallons 60 litres	inches	29.25	26.0	8.75	43.25	40.75	59.25	18.5
			mm	743	660	222	1099	1035	1505	470

Notes:

1. Supply gas through 1/2" pipe. A gas shut-off valve must be installed in supply piping convenient and adjacent to appliance.
2. Electrical connection to be specified on the data plate.
3. Hot & Cold Water: 3/8" OD tubing to Faucet (optional).
4. DRAIN CONNECTION: 1 1/2" NPT drain connection to stand (optional)

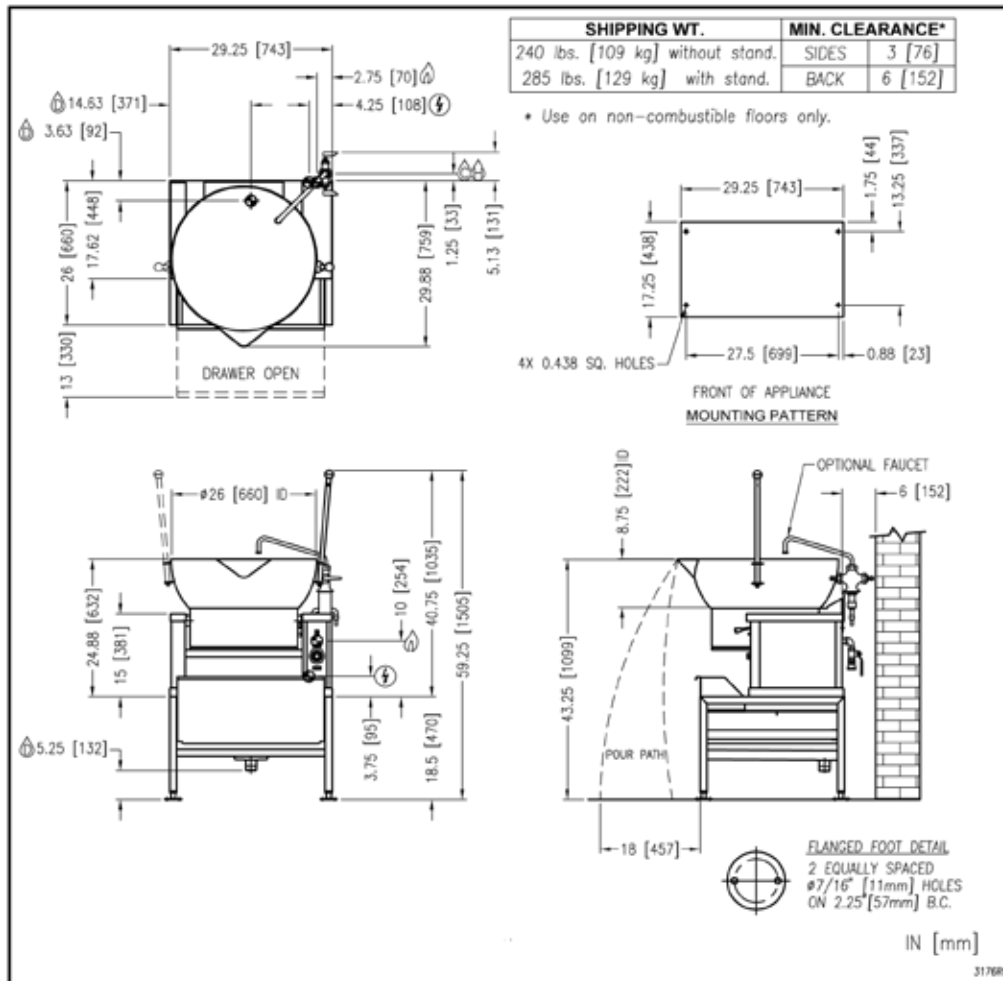

MM6212-1105

AccuTemp Products, Inc.

8415 North Clinton Park • Fort Wayne, IN 46825 • 800-210-5907 • 260-493-0415 • Fax 260-493-0318 • accutemp.net