

Specifications

Description

Adcraft's Portable Oil Filtration System is designed to preserve the life of your oil and ensure consistent fried food quality while saving you money. This model filter can hold up to 40 lbs of oil at one time. This compact, low profile unit is constructed of all stainless steel and mounted on 4 swivel casters for easy movement and storage. The low profile body allows for easy placement under the fryer drain. The included stainless steel cover keeps the unit safe and clean while not in use. This unit is CE Certified and is backed by Adcraft's one year replace or repair warranty.

Construction

- Constructed of heavy duty stainless steel
- Removable flexible filtering hose is 5' long and equipped with a stainless steel nozzle and cool-to-touch handle
- Mounted on 4 (2 locking) swivel casters for easy movement
- Fold down handle allows for safe and easy transporting
- Stainless steel cover keeps unit safe and clean while not in use

Controls

- Separate on/off power switch
- Pump button allows for start/stop of filtering cycle

Filter Chamber

- Large 18"x13" chamber that holds up to 40 lbs of oil
- Includes stainless steel gasket, filter mesh and rubber gasket
- Pumps up to 5 gallons of oil per minute

Electrical

- 1/3 HP motor, 120V, 200W
- 5' removable power cord with NEMA 5-15 plug

Includes

- Filter papers
- Filter powder
- Stainless steel cover

Certifications/Approvals



Portable Oil Filtration System

Models:

- OF-40



Separate "power" and "pump" controls



Oil Filter shown with stainless steel cover (included)

Warranty: This product is protected by Admiral Craft Equipment Corporation's 1 year limited warranty. Should your product fail under normal use it will be repaired or replaced up to 1 year from date of purchase.



Date: _____
 Item No.: _____
 Project No.: _____

Portable Oil Filtration System - OF-40

Plan View

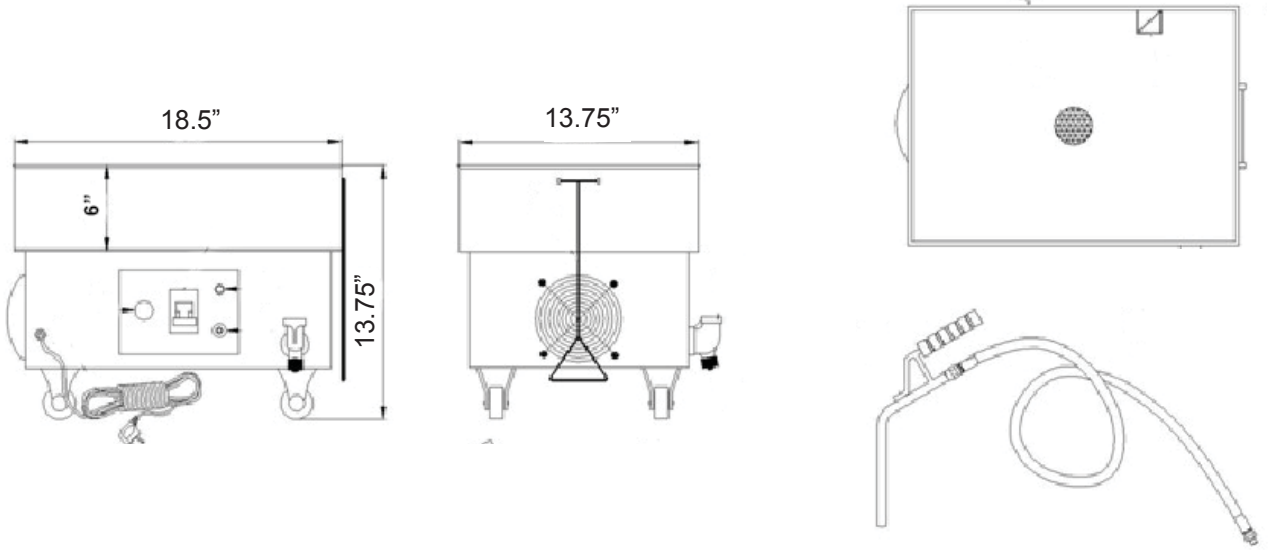

Filtering hose is 5' long with a 1' nozzle

Specifications

Item Number	Description	Horsepower	Oil Capacity	Volts	Wattage	NEMA Plug
OF-40	40 lb Portable Oil Filter	1/3 HP	40 lbs	120V	200W	5-15P 

NOTE: This unit pumps 5 gallons of oil per minute.

Shipping Info

Item Number	Box Dimensions	Item Dimensions	Gross Weight	Net Weight
OF-40	24.5"x19.25"x 19.25"	18.5" x 13.75" x 13.75"	108 lbs	92.5 lbs

For more information about this or any of our other products go to www.admiralcraft.com. This item is listed on AutoQuotes. For full explanation of warranty coverage on this product please refer to warranty page located in the owner's manual and warranty section at www.admiralcraft.com. Specifications subject to change without notice. Please confirm at time of order.