

Item No.

Superior Performance With Exceptional Recovery For High Volume Electric Frying.

High efficiency ribbon-type immersion heaters provide efficient energy transfer for fast frying and quick recovery to increase cooking output of the fryer. Low watt density design prolongs the life of the elements and prevents scorching the shortening. Heaters swing up out of the way for ease of cleaning and access to the large cold zone.

STANDARD FEATURES

- Stainless steel frypot has a **10 year warranty.**
- Stainless steel front panel, trim and door.
- Sealed construction immersion type heating elements made of a high temperature alloy with a stainless steel sheath.
- Heating elements lift up out of the way for easy cleaning of the frypot.
- Redundant contactors and hi-limit control for increased safety.
- Power, heating, and hi-limit lockout indicator lights are mounted conveniently on the front panel.
- Lexan faced control panel is recessed to protect controls from damage.
- Built-in circuit breaker and fuse holder mounted inside front door for easy access.
- Front 1-1/4" full port drain valve for easy no clog cleaning.
- Available with 2 heavy duty automatic basket lifts (14EL-17AA)
- Solid state thermostat for precise temperature control



Model 14EL - 17 shown with optional casters

A N E T S
GoldenFRY™



Anets 14" High Efficiency Electric Fryer

Model 14EL-17/AA



SPECIFICATIONS

- Model 14EL-17, Electric Fryer
14EL-17AA, Electric fryer with automatic basket lifts
- Certification ETL, CETL, NSF
- Electrical Requirements Three phase, 17KW
208V-48A, 240V-42A, 480V-21A
- Thermostat Solid state
- Thermostat Range 200°-375°F (93°-190°C)
- Hi-Limit Safety control shuts off power at 450°F (232°C)
- Frypot Stainless steel welded construction
- Cabinet All Stain Steel construction excluding rear and bottom braces
- Shortening Capacity 40-50 lbs.
- Cooking Capacity 80 lbs. french fries per hour
- Frying Area 14 x 14.5 in (36 x 37cm)

STANDARD ACCESSORIES

- Solid state thermostat
- 2 Nickel plated twin baskets
- 6 Adjustable chrome plated legs
- Drain pipe extension
- Integral basket support
- Clean out rod

OPTIONS AND ACCESSORIES

- Fri-Tronic™ 12-product controller
- Built-in Filter Systems
- Automatic twin basket lifts (14EL-17AA)
- Stainless steel sides
- Casters
- Fryer cleaning brush
- Single or triple baskets (not available on automatic lift models)
- Front Drain tray
- Cover

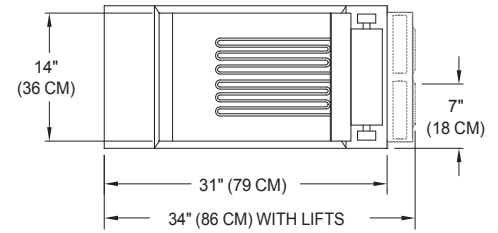

Top View

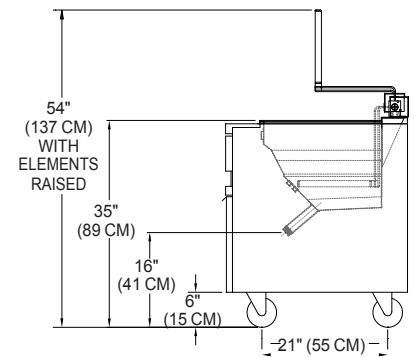

Side View with Lifts

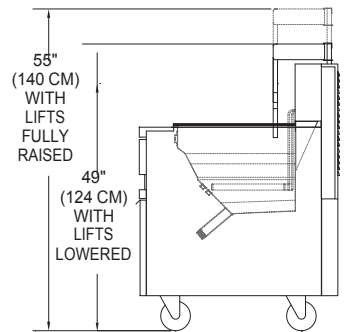

Front View

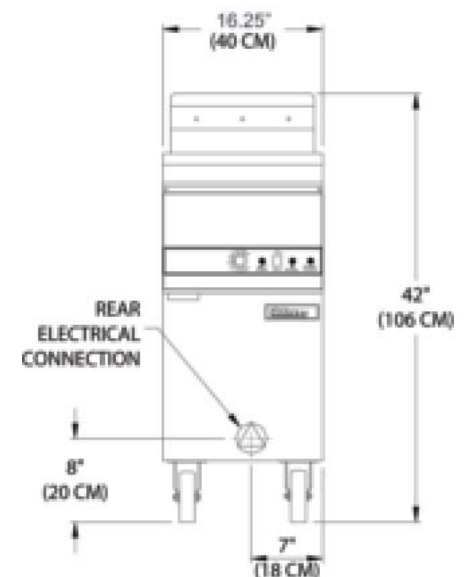

ANETS INC PO BOX 501, CONCORD, NH 03302-0501
509 ROUTE 3A, BOW, NH 03304 TEL: 603-225-6684, FAX:603-225-8497
L10-491 R1 www.anets.com

We reserve the right to change specifications without notice and without incurring any Obligation for equipment previously or subsequently sold.