

Item No.

Reliable Even-Cooking Griddle Provides Outstanding Performance for Breakfast, Lunch or Dinner Menu Items

This series of griddles features exclusive plate temperature sensors which respond to temperature fluctuations quickly. **Individual thermostatically controlled burners every 12 inches (30.5 mm)** maintain consistent temperatures under heavy load conditions. Precise thermostats allow separate heat zones for different products. Cook foods to golden perfection with Anets GoldenGrill™ Gas Griddle.

STANDARD FEATURES

- High nickel content 3/4" (1.9 cm) Precision ground hot rolled steel plate
- One burner per 30,000 BTUH (8.8kW) (32Mj) per burner
- Stainless steel front, sides, grease trough and splashguards
- Snap action thermostats
- Spark ignitor for lighting pilots
- 100% gas safety valve shut-off
- Double wall construction keeps the operator and kitchen cool
- No electrical connection required
- Front grease trough allows for more usable griddle surface
- Extra large grease chute opening equipped with built in spatula scraper
- Large capacity 5.7 quart (5.39 L) grease drawer easily accessible under cabinet and equipped with anti-splash guards. (72" model is equipped with 2 drawers)
- Griddle top 1 year warranty



A24X48G shown on legs



A24X48G shown on optional stainless steel stand with undershelf

A N E T S
GoldenGRILL™





SPECIFICATIONS

Model	AG Models (See Chart below)
Certification	CSA, NSF, CE
BTUH/kW/mjh	30,000 / 8.8 / 32
Gas Pressure	NG 3.5" WC (8.7 mbar) (0.87 kPa) LP 10" WC (25 mbar) (2.5 kPa)
Gas Connection	3/4" NPT (1.9 cm) (19 mm)
Electrical Requirments	None
Plate	High nickel content 3/4" (1.9 cm) precision ground hot rolled steel plate
Burners	Aluminized steel
Themostats	Gas operated, snap action
Temperature Range	200° to 550°F, (93°-288°C)
Safety Pilots	100% gas shut off valve
Spark ignitor	Piezo electric
Cabinet	Front, sides, trough and splashguard, stainless steel back, aluminized steel

STANDARD ACCESSORIES:

- Safety pilots
- Stainless Steel Sides
- Spark ignitor
- 4" (10.2 cm) adjustable chrome plated legs
- Chrome Griddle Cleaning Kit (SGC)
 - 4" (10.2 cm) Scrapper w/ 10 replacement blades
 - 1 can ANETS ALLSHINE cleaner
 - Cleaning brush

OPTIONS AND ACCESSORIES:

- Removable cutting board and bracket assembly
- Stainless steel stand
- Companion griddle stand use griddle stand model AGS
- 11" inch (28 cm) High backsplash

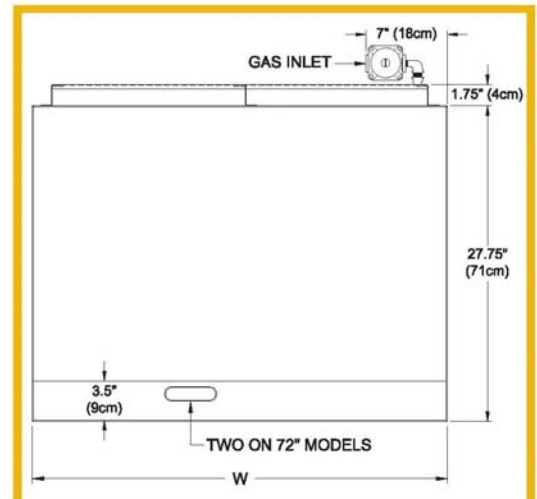

Top View

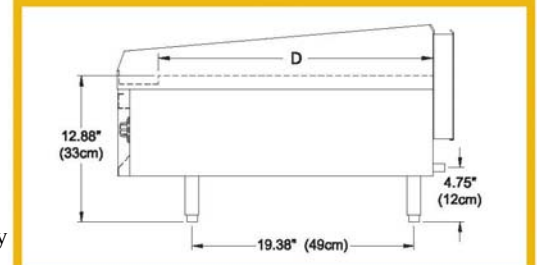

Side View

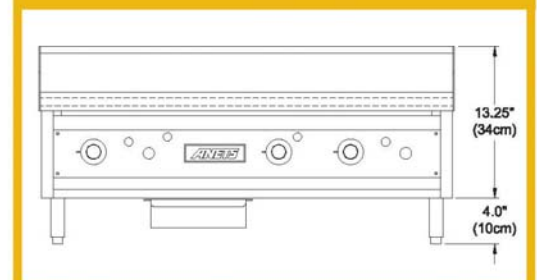

Front View

DIMENSIONS						
24 MODELS						
Overall		A24x24G	A24x36G	A24x48G	A24x60G	A24x72G
	(W) Width	24.25" (61.6 cm)	36.25" (92.1 cm)	48.25" (122.5 cm)	60.25" (153.1 cm)	72.25" (183.5 cm)
	Height	17.25" (43.8 cm)	17.25" (43.8 cm)	17.25" (43.8 cm)	17.25" (43.8 cm)	17.25" (43.8 cm)
	Depth	29.75" (75.5 cm)	29.75" (75.5 cm)	29.75" (75.5 cm)	29.75" (75.5 cm)	29.75" (75.5 cm)
Plate	Width	24" (61 cm)	36" (91 cm)	48" (122 cm)	60" (152 cm)	72" (183 cm)
	(D) Depth	24" (61 cm)	24" (61 cm)	24" (61 cm)	24" (61 cm)	24" (61 cm)
	NG BTUH	60,000	90,000	120,000	150,000	180,000
	LP BTUH	(17.6 kW)	(26.4 kW)	(35kW)	(44kW)	(53kW)

Current construction on 24",36" and 48" wide griddles are 1/2" (1.27 cm) (12.7 mm) taller than indicated in drawing. Current construction subject to change. Contact factory for current dimensions if required.



ANETS INC PO BOX 501, CONCORD, NH 03302-0501
 509 ROUTE 3A, BOW, NH 03304 TEL: 603-225-6684, FAX:603-225-8497
 L10-516 R4 www.anets.com

We reserve the right to change specifications without notice and without incurring any Obligation for equipment previously or subsequently sold.