

AR-7E/GC

GREASE COLLECTION SYSTEM

- Convenient method of grease collection and disposal that operates without supervision.
- Collection system is designed to save labor and provide greater employee safety by eliminating the need to handle hot grease in shallow pans.
- Grease trolley stores conveniently underneath the rotisserie oven.
- Interior collection pan drains into the removable Grease Collection Pan via the telescoping drain line
- Chicken grease and other by-products are channeled into the drain line to empty directly into a mobile tank located below the oven.
- Holds accumulated grease and by-products from multiple batches of chicken during the work day.
- Mobile tank is easily rolled to the grease disposal site to be emptied as needed.

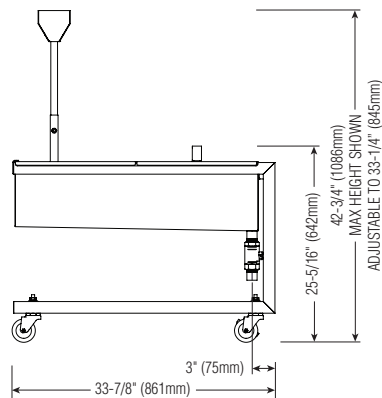
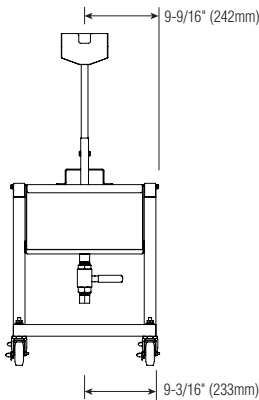
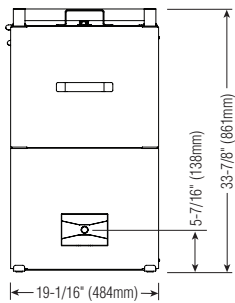

INSTALLATION REQUIREMENTS

- Oven must be installed level.
- Exhaust ventilation is required.
- Oven must be mounted on oven stand, FR-26550 (purchased separately).
- 6" (152mm) clearance on left, right and rear sides.

