



- Battery companion for ASF-60 or ASF-75 gas and electric fryers or stand-alone dump station
- Maintenance free overhead 1,000 watt infrared warmer
- Stainless steel front and sides
- Removable 1/3 size pan to collect crumbs
- Four leveling casters
- Bank individual fryers, dump stations, and utility cart side by side with gap cover strips.
- One year parts and labor warranty

The Alto-Shaam ASF-60DS dump station is constructed of stainless steel and includes front and rear-mounted, heavy duty leveling casters. An overhead infrared heating element is controlled with one (1) ON/OFF power switch. Holding well includes a screen insert to collect crumbs and small bits of product in a removable catch pan located behind the door. Stand-alone dump station or battery companion for gas or electric fryers. Unit can be banked to the right, left, or between fryers. Must be placed on far left or right when included in a battery configuration.

ASF-60DS Fryer Dump Station



FACTORY INSTALLED OPTIONS

- Specify Voltage:
 - 120
 - 230
- ASF-60 Fryer Dump Station Battery
 - Create a battery of multiple ASF-60E, ASF-60G fryers, ASF-60DS dump stations, and ASF-60UC utility cart in any combination of up to four (4) units. Must order a minimum of two units. Units sold separately.
 - Battery configuration includes oil filtration system. Specify right- or left-side placement when ordering.

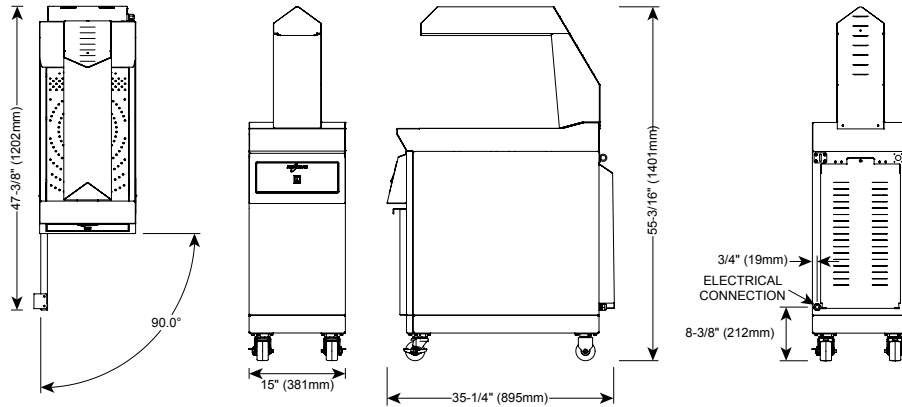

CAPACITY
18 lb (8.2 kg) MAXIMUM

DIMENSIONS EXTERIOR H x W x D:
55-3/16" x 15" x 35-1/4" (1401mm x 381mm x 895mm)
36-11/16" (931mm) unit height without infrared warmer

WEIGHT EST.	NET WEIGHT	SHIP WEIGHT
	CONTACT FACTORY	CONTACT FACTORY
CARTON DIMENSIONS:	CONTACT FACTORY	

INSTALLATION REQUIREMENTS
Dump station must be installed level.

CLEARANCE REQUIREMENTS
BACK: 6" (152mm) FRONT: 25" (635mm)

ELECTRICAL					
VOLTAGE	PHASE	CYCLE/HZ	AMPS	kW	CORD & PLUG
120	1	60	8.3	1.0	NEMA 5-15P 15A-125V PLUG 40" (1016mm) CORD
230	1	50	4.3	1.0	CEE 7/7 16A-250V PLUG 40" (1016mm) CORD

OPTIONS
<input type="checkbox"/> Banking Strip (1 STRIP REQ'D FOR EVERY 2 BANKED UNITS) 1013504