



ASF-60UC

FRYER UTILITY CABINET



- Battery companion for gas and electric fryers or stand-alone utility cabinet
- Stainless steel front and sides
- Four leveling casters
- One year parts and labor warranty

The Alto-Shaam ASF-60UC utility cabinet is constructed of stainless steel and includes one (1) set of heavy duty leveling casters, two (2) rigid and two (2) swivel with brake. Cabinet features three (3) shelves behind the front access door. Door has a grab handle and magnetic closure. Stand-alone utility cabinet or battery companion for gas or electric fryers. Must be placed on far left or far right when included in a battery configuration.

ASF-60UC Utility Cabinet (5015856)

FACTORY INSTALLED OPTIONS

- ASF-60UC Utility Cabinet Battery
- Create a battery of multiple ASF-60 fryers, ASF-60DS dump stations and ASF-60UC utility cabinets in any combination of up to four (4) units. Must order a minimum of two units. Units sold separately. Battery configuration can include oil filtration system. Specify right- or left-side placement when ordering.



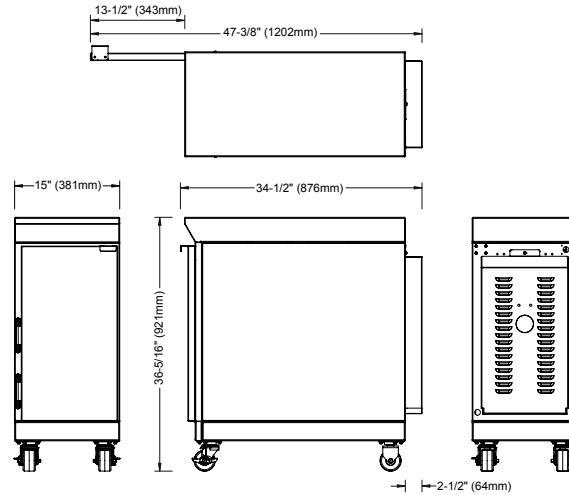

DIMENSIONS EXTERIOR H x W x D:
36-5/16" x 15" x 34-1/2" (921mm x 381mm x 876mm)

WEIGHT	NET WEIGHT	SHIP WEIGHT
	94 lb	CONTACT FACTORY
CARTON DIMENSIONS:	53" L x 45" W x 65" H (1346mm x 1143mm x 1651mm)	

INSTALLATION REQUIREMENTS
Utility cabinet must be installed level.

CLEARANCE REQUIREMENTS
BACK: 0" (0mm) FRONT: 25" (635mm) SIDES: 0" (0mm)