

# ITM2-48

## ISLAND TAKEOUT MERCHANDISER



• Freestanding, self-service merchandiser designed to provide quality hot packaged foods with minimum labor costs.

- Lighted display maximizes visual merchandising — promotes impulse sales.
- Heat source radiates from the base and the upper canopy with adjustable temperature settings.
- Concealed power and temperature switches are easily accessible to the operator.
- Angled canopy on two sides adds to the clean streamlined look.
- Bumpers on two sides of the unit provide extra protection against damage from shopping carts.
- Available as standard with stainless steel base, black side panels, and black shelving.

20 gauge stainless steel island base features bumpers on two sides, comes standard with two (2) black painted side panels and two (2) black painted adjustable shelves. An easy to clean hard coat anodized heat plate is surrounded by 2-1/2" (64mm) removable heat guards. The overhead canopy is supported by two (2) side supports, enclosing six (6) flood lamps and is surrounded by four (4) removable tinted lexan heat guards. Two (2) toggle switches located beneath the canopy control the power (ON/OFF) and the heat plate temperature (LOW/MEDIUM/HIGH). The base is furnished with four (4) 5" (127mm) casters, 2 rigid, and 2 swivel with brake.

Deluxe model features black formica end panels and black painted canopy, four (4) wooden adjustable shelves, and two removable wooden end baskets.

- 
- MODEL ITM2-48/STD:** Island Take-out Merchandiser, 48" wide
  - MODEL ITM2-48/DLX:** Deluxe Island Take-out Merchandiser, 67" wide
- 



### FACTORY INSTALLED OPTIONS

- Panel Color Choices
  - ➔ Specify color choice:
    - Black, standard
    - Stainless Steel, optional
    - Custom Color, optional
- Full Side Guards, Lexan

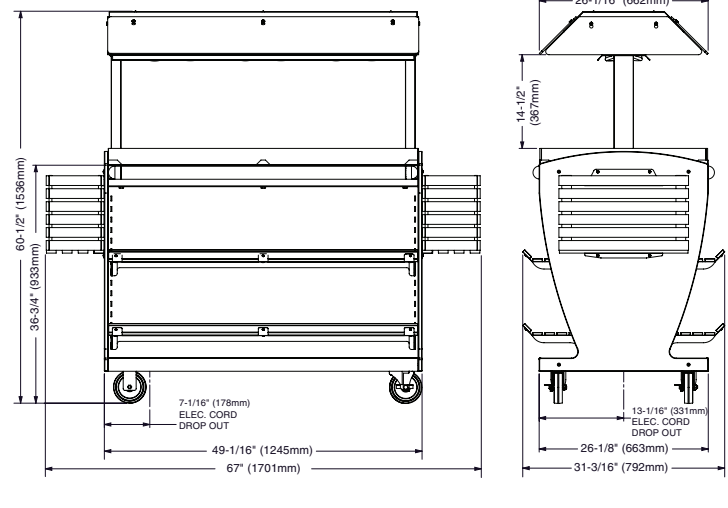
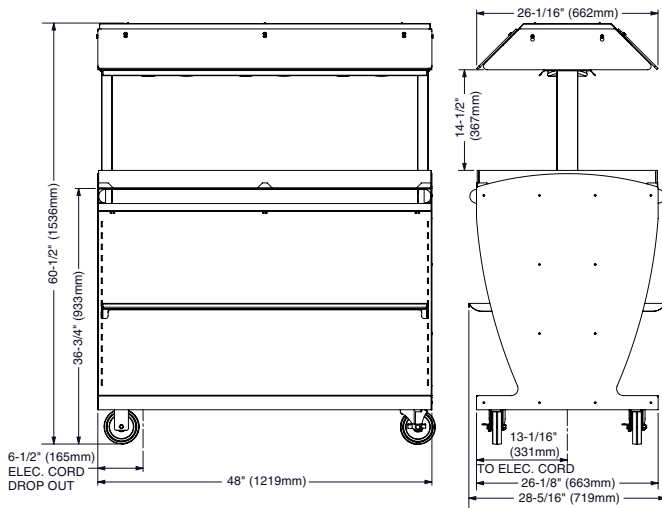
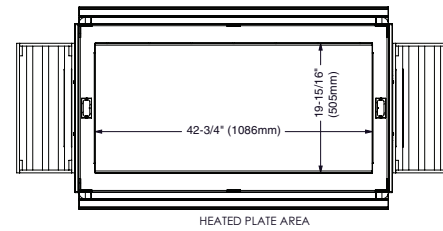
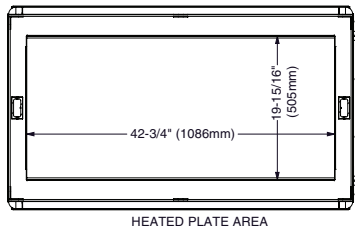

**ITM2-48/STD**

**ITM2-48/DLX**

<b>WEIGHT</b>		
	ITM2-48/STD	ITM2-48/DLX
<b>NET</b>	255 lb (116 kg)	285 lb (125 kg)
<b>SHIP</b>	389 lb (176 kg)	425 lb (193 kg)
<b>CRATE DIMENSIONS:</b> (L x W x H)		
60" x 38" x 68"		
(1524mm x 965mm x 1727mm)		

<b>INSTALLATION REQUIREMENTS</b>
Unit must be installed level, and must not be installed in any area where it may be affected by steam, grease, dripping water, high temperatures, or any other severely adverse conditions.

<b>CLEARANCE REQUIREMENTS</b>
NO CLEARANCE REQUIRED

<b>DIMENSIONS:</b> H x W x D
<b>STANDARD:</b>
60-1/2" x 48" x 28-5/16" (1536mm x 1219mm x 719mm)
<b>DELUXE:</b>
60-1/2" x 67" x 31-3/16" (1536mm x 1701mm x 792mm)
<b>HEATED SURFACE DIMENSIONS:</b> (L x W)
42-3/4" x 19-15/16" (1086mm x 505mm)

<b>ELECTRICAL</b>						
VOLTAGE	PHASE	CYCLE/HZ	AMPS	kW	CORD & PLUG	
120	1	50/60	11.0	1.32		NEMA 5-15P 15A - 125V Plug
230	1	50	6.1	1.40	CORD INCLUDED NO PLUG	

<b>HEATED PRODUCT CAPACITY*</b>
36 lb (16 kg) MAXIMUM
Twelve (12) chicken boats with dome cover
DOME PACKAGE SIZE: APPROX. 7" x 10" (178mm x 254mm)
*FOR USE WITH PRE-PACKAGED ITEMS ONLY