



**BLAST CHILLERS / SHOCK FREEZERS
(Roll-In, Remote Refrigeration)
Models: AP24BCF300-3 / AP40BCF450-3**

JOB _____
ITEM # _____
QTY. REQUIRED _____

AIA FILE # _____

SPEC # _____

SPECIFICATIONS

SCOPE: This specification covers the models AP24BCF300-3 and AP40BCF450-3 HurriChill™ Blast Chillers/Shock Freezers. They are complete with all required controls and accessories. Remote condensing unit sold separately. Several options are also available.

GENERAL: The microprocessor control system provides a choice of operating cycles: soft chilling, hard chilling, shock freezing, holding, sterilizing, defrosting, and heating the core probe. One heated core temperature probe is provided for accurate control of temperature within the product. An optional strip recorder provides a record of the unit's operating parameters during the cycle and the following holding period. The information recorded includes date, time, cycle identification, product identification, and product core temperature at prescribed intervals. Model AP24BCF300-3 is sized for one mobile rack (not included) holding up to (26) 12" x 20" x 2-1/2" steam pans or up to (13) 18" x 26" sheet pans while the AP40BCF450-3 can accommodate (40) steam pans or (20) sheet pans.

PERFORMANCE: Blast chilling (soft or hard) lowers the food core temperature from 160°F to 38°F within 90 minutes. Shock freezing lowers the core temperature from 160°F to 0°F within 4 hours. Chilling times will vary somewhat, depending on the food quantity, initial temperature, density, moisture content, specific heat, and type of container. The airflow has a high velocity, indirect pattern designed to cool all levels at identical rates. Time/temperature chilling rates meet or exceed all FDA and state regulations.

CONSTRUCTION: The chilling cabinet is constructed of polished type 304 stainless steel, with 3-1/4" of CFC-free, high density polyurethane insulation. The interior corners are fully rounded. The door is equipped with a removable magnetic gasket. All motors are sealed ball bearing wash-down type. The cabinet floor is insulated (1/2" CFC-free high density polyurethane) and is provided with an integral 3" long ramp to facilitate access. A minimum 15" clear space is required above the cabinet for service. A minimum 6" clear space is required on the control panel side of the cabinet for service. A minimum 12" clear space is required on the hinge side of the cabinet for door opening.

REFRIGERATION SYSTEM: The refrigeration system as furnished by manufacturer is complete with all components, including controls, evaporator and blower system. The evaporator is of the forced convection type and designed specifically for blast chilling/shock freezing operation. Air circulation motors, multi-fin and tube type coils, and fan guards are contained within the cabinet. Also included in the cabinet are the liquid line solenoid valve, thermostatic expansion valves, the inlet and outlet connections, and a drain connection. Access to the evaporator for cleaning shall be via a convenient hinged, swing-out ventilator panel. Fan motors have inherent overload protection and the fan blades are guarded to prevent injury.

MICROPROCESSOR CONTROL SYSTEM: The solid state electronic control panel is user friendly, easy to reach, and can be set for automatic or manual operation. The heated food probe continuously measures the product temperature during the chilling or freezing cycles. At the end of a freezing cycle the probe can be heated for ease of removal from the frozen product. Easy to read VFD display and buzzer alarm are standard features.

All settings are programmable by the operator. The standard operating cycles include the following:

- Soft Chilling:** The air temperature is held in the range of 28°F to 35°F, ideal for delicate food items. The chilling cycle is completed when the food core temperature reaches 38°F to 40°F.



- Hard Chilling:** The air temperature is lowered to 0°F. When the food core temperature reaches 60°F, the air temperature rises to a range of 28°F to 35°F. The chilling cycle is completed when the food core temperature reaches 38°F to 40°F.
- Shock Freezing:** This cycle is designed to avoid damage to the food structure, keeping the food free of large ice crystals. The air temperature is lowered to and held at -25°F. The freezing cycle is completed when the food core temperature reaches 0°F.
- Thawing (Optional):** Air temperature is carefully monitored and alternates between gentle heat and refrigeration to safely thaw food product.
- Holding:** At the end of any cycle (soft chilling, hard chilling, and shock freezing), the unit will automatically switch to a holding mode which will keep the food at 38°F (blast chilling) respectively 0°F (shock freezing) until the cycle is stopped.

ADDITIONAL FEATURES:

- Heated Core Probe:** If the product will get under 30°F then you can use this cycle to extract the probes.
- Defrost:** An automatic defrost cycle is factory preset and will initiate after each 24 hours of operation. A manual defrost override can be selected at any time at the user's discretion.
- Batch Names:** Store up to 150 batch names that can be used to help identify cycle runs within HACCP reports.

BLAST CHILLERS / SHOCK FREEZERS (Roll-In, Remote Refrigeration)
Models: AP24BCF300-3 / AP40BCF450-3



Details and Dimensions



BLAST CHILLERS / SHOCK FREEZERS (Roll-In, Remote Refrigeration) Models: AP24BCF300-3 / AP40BCF450-3

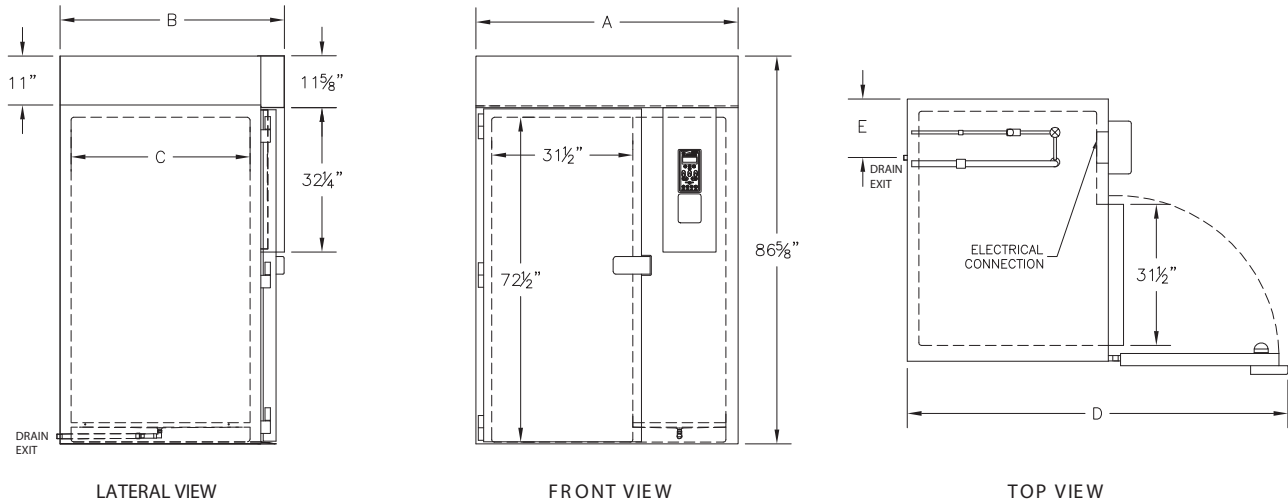

CABINET DATA	FOOD LOAD PER CYCLE [LBS]		CABINET DIMENSIONS [IN]					CABINET ELECTRICAL				SHIPPING WEIGHT [LBS]	
	MODEL	160°F TO 38°F	160°F TO 0°F	A	B	C	D	E	V	PH	HZ		A
AP24BCF300-3	300	180	54-3/8	46-1/4	35-3/4	81	11-1/4	208	3	60	8	15	1,240
AP40BCF450-3	450	270	59	50-1/8	40	85	13-1/8	208	3	60	10	15	1,390

REFRIGERATION DATA	CAPACITY [BTU/H] AT: 14°F EVAP. TEMP 105°F COND. TEMP	REFRIGERANT	DISCHARGE LINE [IN] (UP TO 60 FT)	SUCTION LINE [IN] (UP TO 60 FT)	CONDENSING UNIT (OPTIONAL)
MODEL					
AP24BCF300-3	50,000	404A	5/8	1-3/8	LOW / MED TEMP 40°F TO -40°F
AP40BCF450-3	70,000		5/8	1-3/8	

OPTIONS:

- Sterilizing:** The ultraviolet system sterilizes all metal surfaces within the cabinet in a preset time of 30 minutes. The mirror finish of the cabinet interior is specifically designed to optimize the performance of the UV cycle. The system is not intended to sterilize food.
- Printer:** A strip recorder provides a record of the unit's operating parameters during a cycle and the following holding period. The information recorded includes date, time, cycle identification, recipe name, and product core temperature at prescribed intervals.
- Label Printer:** Clearly label food product with a product name and information regarding the product's life cycle throughout the entire chilling/freezing process.
- Four Food Probes:** One heated food probe is standard. Four heated food probes can be provided as an option.
- Automated Report Documentation (ARD) Software Package:** Allows for complete two-way communication between the unit and a remote PC. Supported functions include programming, system diagnostics, operation, and downloading of data for HACCP compliance.
- Mobile Racks:** Model AP24BCF300-3 can accommodate one mobile rack with maximum dimensions of 27" wide, 30-1/2" deep and 72" high. Model AP40BCF450-3 can accommodate one mobile rack with maximum dimensions: 29" wide, 37" deep and 72" high.
- Thaw Cycle Module:** Allows unit to be used as a thaw cabinet and includes a non-heated thaw probe.
 - Automatic Mode:** Air temperature is controlled by monitoring the food product using a non-heated probe. Once the product reaches 38°F the cycle is complete and the unit switches into holding mode.
- Rear Door:** For pass-thru operation (increases depth by 3")
- Prison Security Package.**
- Air-Cooled Remote Condensing Unit.**
- Water-Cooled Remote Condensing Unit.**

INSTALLATION: A detailed installation manual is provided. It must be carefully followed to ensure proper operation and to protect your rights under the warranty.

WARRANTY: The warranty covers all parts found to be defective and the labor required to replace them for a period of one year from the date of shipment.

