

PRODUCT:

QUANTITY:

ITEM:

Designed Smart

- The M-83 Bun Grill toaster can generate up to 1600 bun halves per hour. .
- Bun Grill is available with extended superfeeder to allow for high volume production.
- Fast heat-up allows your operation to react to surges in volume.
- Patented “self-leveling” conveyor automatically adjusts to various sizes of buns, bagels, and Texas toasts.
- Butter roller and pan consistently covers buns with the perfect amount of butter.
- Durable steel griddle plate is controlled with an electromechanical thermostat adjustable to temperatures from 200 to 500 degrees.
- Removable side panel allows easy access for service.
- Front panel is easy to remove. Conveyor belt lifts out for easy cleaning. Allows direct access to clean griddle surface.



Model M-83

Options

- PTFE Sheet Kit (10) sheets (87449)
- Speed up gear: fast speed – 26 sec. (85048)
- Slow down gear: med. speed – 45 sec. (85045)
- Slow down gear: slow speed – 85 sec. (85050)
- Bun Superfeeder, Factory reconditioning kit (89525)

APW Wyott Design Features

- Compact, vertical design allows unit to fit into tight counter areas.
- Stainless steel construction will provide years of toasting performance.
- Nickel plated steel griddle plate stands up to years of grilling and cleaning.
- High temperature insulated wire and electric components are used for long life.
- 6” feeder, “butter” roller and “butter” pan standard.
- 1/2” griddle plate for better heat distribution.
- Fast warm up.
- Permanent grill surface-never needs replacing.
- Use wet or dry.
- Adjustable legs.
- Snap-lock construction, easy to clean.

Reliability backed by APW Wyott's Warranty

All APW Wyott Toasters are backed by a 1-year parts and labor warranty, including on-site service calls within 50 miles of authorized service technicians.

•Certified by the following agencies:



See reverse side for product specifications.

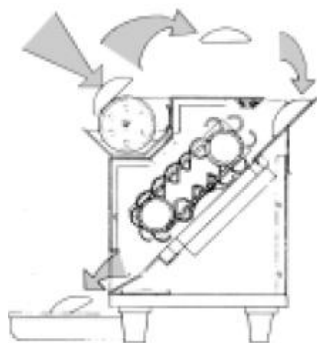
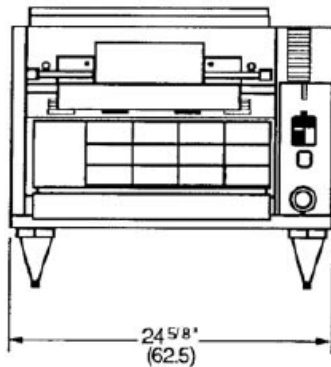
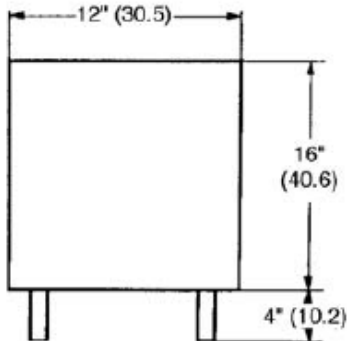

Standard Feeder
(Adds 11" to height of base unit and adds 4 1/2" to depth)

PRODUCT PATH

Consultant Specifications

Toasters are constructed of stainless steel and aluminum material. Range of belt speeds should be 28 to 75 seconds. Front corners and front conveyor guard should be painted. Toasters furnished with 1" adjustable legs. Infrared metal sheathed radiant heaters are located on the top and bottom and are individually controlled by Infinite Heat Controls. On/Off switch has Indicator Light that glows when the toaster is on. Power saver switch will be supplied that reduces energy by 50%. Product opening is 1 1/2". motors are permanently lubricated. Toaster will be Air Cooled with a thermostatically controlled fan that stays on until the toaster is cool to the touch. Control area has cooling fan. Units are UL listed, UL Sanitation, and Canadian UL approved.

PRODUCT SPECIFICATIONS:

Construction:

Constructed of heavy-duty stainless steel. Nickel plated steel griddle plate. Adjustable legs.

Electrical Information:

Each unit is equipped with a 39", three wire grounded power cord which terminates with a standard three pronged male plug. The 120V unit uses a NEMA 5-15P plug. The 208V/240V, use a NEMA 6-20P plug.

Electrical Specifications;

M-83: 120V, 1600W, 13.3Amps
 M-83: 208V, 1600W, 7.7Amps
 M-83: 240V, 1600W, 6.7Amps

Capacity:

M-83: up to 1600 pieces per hour

Overall Dimensions:

M-83: 20"H x 24 5/8"W x 12"D
 M-83: 31H x 24 5/8"W x 16 1/2"D
 (with Superfeeder)

Shipping:

M-83: 97 lbs.

Freight Class: 100

FOB: Standex Dock

*APW Wyott reserves the right to modify specifications or discontinue models without incurring obligation.