



Evolution Series Recessed Cold Food Counter

With Alluserv you are not just buying a product. You are receiving our team's service commitment to get the most value from your investment in our products. We will provide you with:

- A team of knowledgeable experts with over 100 years of combined experience to help you understand and receive the most from your product throughout its service life
- Detailed instructions and specification on cleaning and application to best maintain your equipment
- A national service network and service manuals for our extensive product offering.

Model Numbers:
ACF9C2, ACF9C3, ACF9C4,
ACF9C5, ACF9C6

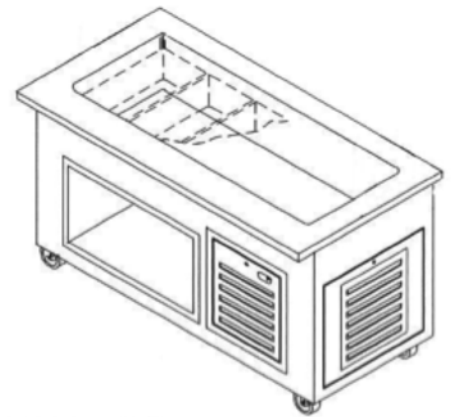

RECESSED COLD FOOD COUNTER

APPLICATION

The Evolution Series counters can support any tray line layout and are versatile enough to use in any format.

CONSTRUCTION

The cold food counter is constructed with heavy duty gauge stainless steel and is equipped with stainless steel counter tops as standard, as well as a stainless steel under shelf. The front panels will be easily removable and replaceable, allowing front service access. The body will be reinforced with vertical galvanized steel channel supports. All units come standard with an 8' long cord and plug.

Options

- Solid surface tray slide
- Protector guards
- Stainless steel legs in lieu of casters
- Fluorescent lights
- Drop down work shelf
- Hinged door
- Flush mounted duplex outlet
- Single fill faucet

Warranty

- One year parts and labor

Recessed Cold Food Counter

COUNTER TOP

The top will be 32 1/2" wide and made-up from a heavy duty gauge stainless steel with square turndown on all sides and corner fully welded, ground and polished.

STORAGE COMPARTMENT

Storage compartment is made of 18-gauge stainless steel. The liner will have coved corners and removable top panels to allow for service access.

CASTERS

The unit is mounted on 5" ball bearing, swivel type casters with brakes on all wheels. The casters will be mounted through two stainless steel channels for extra rigidity.

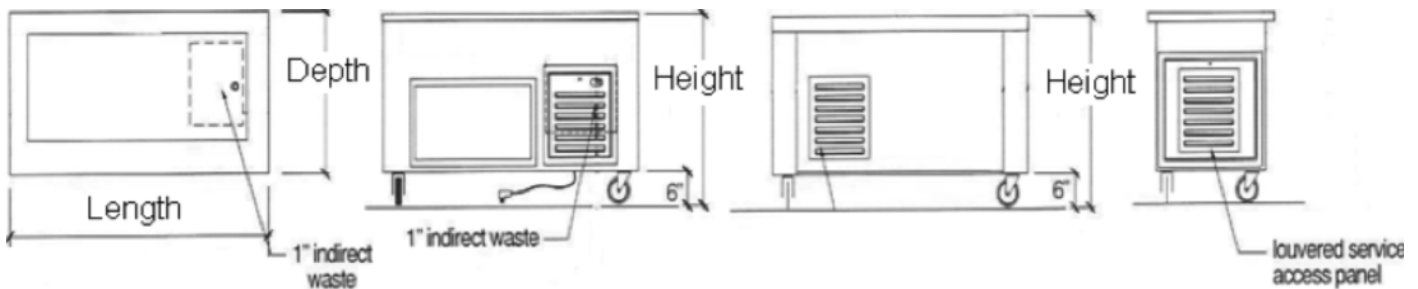

DIMENSIONS

MODEL	OVERALL SIZE			STORAGE COMPARTMENT LENGTH	COMP	NUMBER OF PANS	115V, 1 PHASE		CASE WEIGHT
	D	L	H				AMP	NEMA	
ACF9C2	32-1/2"	38"	36"	n/a	1/6	2	4	5-15P	400 lbs.
ACF9C3	32-1/2"	52"	36"	15"	1/4	3	7	5-15P	450 lbs.
ACF9C4	32-1/2"	66"	36"	28"	1/4	4	7	5-15P	580 lbs.
ACF9C5	32-1/2"	80"	36"	28"	1/4	5	7	5-15P	600 lbs.
ACF9C6	32-1/2"	94"	36"	(2) 28"	1/4	6	7	5-15P	750 lbs.

