

**Merchandiser
Glass Swing Door
Counter Top**

BAGR7



WARRANTY

- 2 Years Parts and Labor, 5 Years on Compressor in USA



Conforms to NSF/ANSI 7

223 W. Rosecrans Ave. Gardena, CA. 90248 USA

Tel : 1.866.677.8500 / 310.808.0102
Fax : 310.808.0242 / 310.808.0262

BAGR7 Merchandiser, Glass Swing Door, Counter Top

Product Specification

MODEL NAME	BAGR7
Product Description	Refrigerator
Capacity(Cu.ft.)	7
Exterior Dimensions(WxDxH)	21 1/4" x 26" x 38 1/4"
Net Weight(lbs)	132
Foot	Adjustable 4
Door Type	1 Glass Door (Swing)
Door Stopper	N/A
Shelves	2 ea
Input	AC 115V / 60Hz
Amps	3.1 A
Compressor(Hp)	1/5 HP
Refrigerant	R-134a
Range of Temperature	32 ~40°F
Easy access for Service	N/A

- CFC-Free polyurethane with high density and energy saving efficiency.
- Refrigerator systems are equipped with an interior vertical fluorescent lights.
- Standard adjustable white epoxy-coated wire shelves
- Triple pane glass door system.
- Refrigeration system is designed to function at 32-40F.
- The interior is composed of high quality coated steel.
- Refrigeration unit uses an Eco-friendly CFC-free R-134A refrigerant.
- Adjustable legs for leveling.

* BLUE AIR has the right to change specifications without further notice.

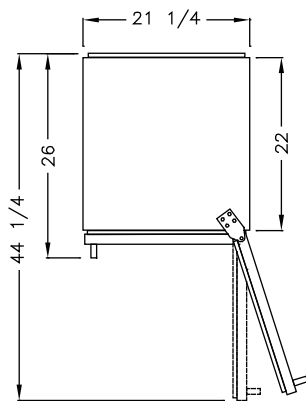

[TOP VIEW]

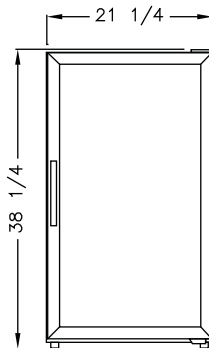

[FRONT VIEW]

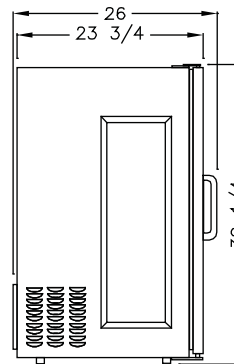

[LEFT VIEW]

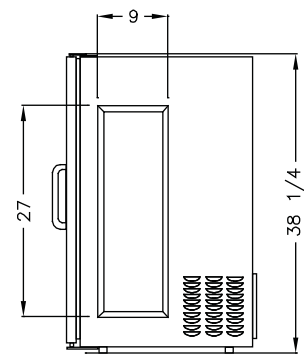

[LIGHT VIEW]

WARRANTY

- 2 Years Parts and Labor, 5 Years on Compressor in USA



BLUE AIR Commercial Refrigeration Inc.

223 W. Rosecrans Ave.
Gardena, CA. 90248 USA

Tel : 1.866.677.8500 / 310.808.0102
Fax : 310.808.0242 / 310.808.0262

<http://www.Blueairinc.com>
Email : info@blueairinc.com