

Mega Top Sandwich Table Refrigerator

BAMT72



WARRANTY

- 2 Years Parts and Labor, 5 Years on Compressor in USA



Conforms to NSF/ANSI 7(ETL)

223 W. Rosecrans Ave. Gardena, CA. 90248 USA

Tel : 1.866.677.8500 / 310.808.0102

Fax : 310.808.0242 / 310.808.0262

BAMT72 Mega Top Sandwich Table

Product Specification

MODEL NAME	BAMT72
Product Description	Refrigerator
Capacity(Cu.ft.)	20
Exterior Dimensions(WxDxH)	72 1/2" x 33 3/4" x 44"
Net Weight(lbs)	328
Foot	Caster 4
Door Type	3 Doors (Swing)
Door Auto Closer	Equipped(Spring)
Shelves	3 ea
Input	AC 115V / 60Hz
Amps	6.1 A
Compressor(Hp)	3/8 Hp
Refrigerant	R-134a
Range of Temperature	32 ~40°F
Easy access for Service	Sliding Condensing Unit
Pans	1/6" x 30 ea

* BLUE AIR has the right to change specifications without further notice.

● **STAINLESS STEEL INTERIOR, EXTERIOR**

The excellent quality of stainless steel help minimizes dents, scratches, and rust. It also maximizes the tensile and bright smooth sheen. In addition our stainless steel offers long-life durability and easy maintenance.

● **5" DIAMETER SWIVEL CASTERS WITH BRAKES FOR THE FRONT**

● **RECESSED DOOR HANDLE**

● **SELF-CLOSING DOOR**

● **STAINLESS STEEL ROLL-BACK COVER IS FOAM INSULATED**

● **SELF CONTAINED SYSTEM**

Simple installation with no plumbing. Comes with a 9 foot long cord

● **CFC-FREE FOAMED-IN-PLACE POLYURETHANE WITH HIGH DENSITY**

With the extra density and high-capacity cells, There is more energy efficiency.

● **ELEGANT ROUND CORNER**

An elegant design with a more stable appearance and safely benefits

● **Conforms to NSF/ANSI 7(ETL).**

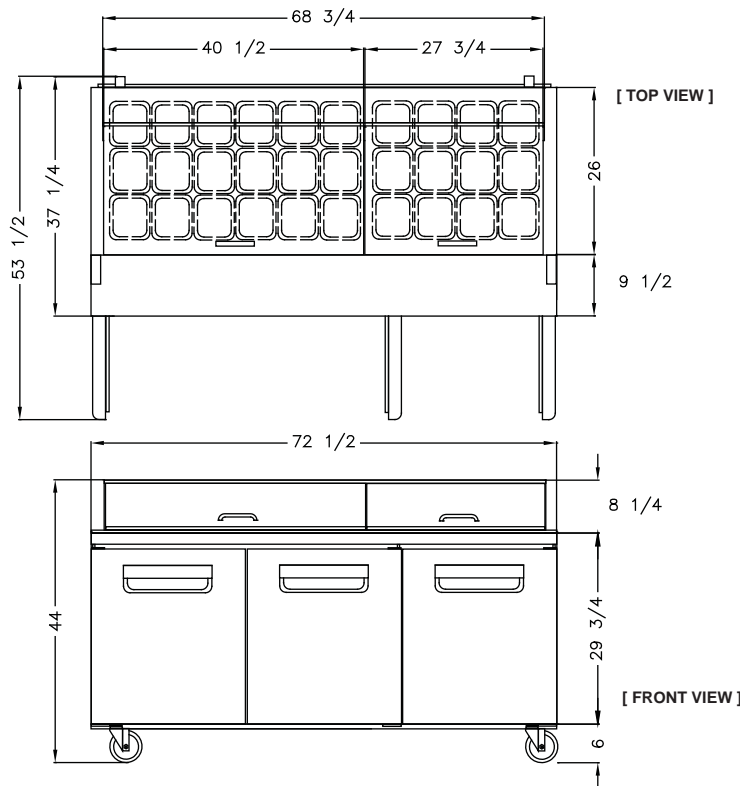

WARRANTY

- 2 Years Parts and Labor, 5 Years on Compressor in USA



BLUE AIR Commercial Refrigeration Inc.

223 W. Rosecrans Ave.
Gardena, CA. 90248 USA

Tel : 1.866.677.8500 / 310.808.0102
Fax : 310.808.0242 / 310.808.0262

<http://www.Blueairinc.com>
Email : info@blueairinc.com