



Sandwich Prep Table Refrigerator

BAPT60

WARRANTY

- 2 Years Parts and Labor, 5 Years on Compressor in USA



223 W. Rosecrans Ave. Gardena, CA. 90248 USA

Tel : 1.866.677.8500 / 310.808.0102
Fax : 310.808.0242 / 310.808.0262

BAPT60 Sandwich Prep Table

Product Specification

MODEL NAME	BAPT60
Product Description	Refrigerator
Capacity(Cu.ft.)	16.5
Exterior Dimensions(WxDxH)	60 1/2" x 30 1/2" x 42 1/2"
Net Weight(lbs)	260
Foot	Caster 4
Door Type	2 Doors (Swing)
Door Auto Closer	Equipped(Spring)
Shelves	2 ea
Input	AC 115V / 60Hz
Amps	6.0 A
Compressor(Hp)	3/8 HP
Refrigerant	R-134a
Range of Temperature	32 ~40°F
Easy access for Service	Sliding Condensing Unit
Pans	1/6" x 16 ea

● **STAINLESS STEEL INTERIOR, EXTERIOR**

The excellent quality of stainless steel help minimizes dents, scratches, and rust. It also maximizes the tensile and bright smooth sheen. In addition our stainless steel offers long-life durability and easy maintenance.

● **5" DIAMETER SWIVEL CASTERS WITH BRAKES FOR THE FRONT**

● **RECESSED DOOR HANDLE**

● **SELF-CLOSING DOOR**

● **STAINLESS STEEL ROLL-BACK COVER IS FOAM INSULATED**

● **SELF CONTAINED SYSTEM**

Simple installation with no plumbing. Comes with a 9 foot long cord

● **CFC-FREE FOAMED-IN-PLACE POLYURETHANE WITH HIGH DENSITY**

With the extra density and high-capacity cells, There is more energy efficiency.

● **ELEGANT ROUND CORNER**

An elegant design with a more stable appearance and safely benefits

● **Conforms to NSF/ANSI 7(ETL)**

* BLUE AIR has the right to change specifications without further notice.

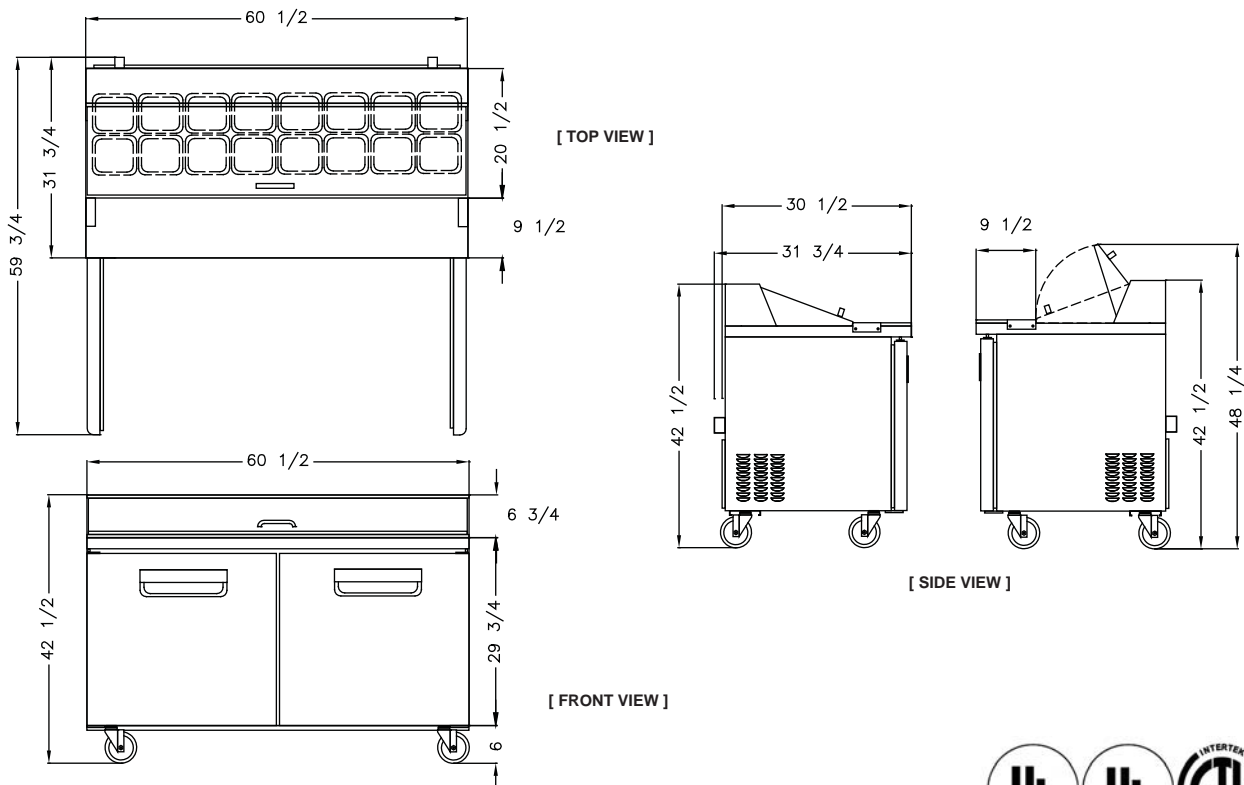

WARRANTY

- 2 Years Parts and Labor, 5 Years on Compressor in USA



BLUE AIR Commercial Refrigeration Inc.

223 W. Rosecrans Ave.
Gardena, CA. 90248 USA

Tel : 1.866.677.8500 / 310.808.0102
Fax : 310.808.0242 / 310.808.0262

<http://www.Blueairinc.com>
Email : info@blueairinc.com