

## Direct Draw Beer Dispenser

**BDD59-2B**

**BDD59-2S**



**WARRANTY**

- 2 Years Parts and Labor, 5 Years on Compressor in USA



Conforms to NSF/ANSI 7(UL)

223 W. Rosecrans Ave. Gardena, CA. 90248 USA

Tel : 1.866.677.8500 / 310.808.0102  
Fax : 310.808.0242 / 310.808.0262

## BDD59-2B(S) Direct Draw Beer Dispenser

### Product Specification

MODEL NAME	BDD59-2B(S)
Product Description	Direct Draw Beer Dispenser
Capacity(Cu.ft.)	19
Exterior Dimensions(WxDxH),without HDL	59 1/8" x 27 1/8" x 37"
Net Weight(lbs)	276
Door Type	2 Solid Door (Swing)
Door Stopper	Yes
Barrels(1/2)	2 ea
Input	AC 115V / 60Hz
Amps	6.3 A
Compressor(Hp)	3/8 HP
Refrigerant	R-134a
Range of Temperature	32 ~40°F

\* BLUE AIR has the right to change specifications without further notice.

- Forced Air Cooling System
- Side-mount Compressor left side with extra ventilation
- Available Black vinyl finish(B) or Stainless(S)
- Galvanized Interior and Stainless Steel Floor
- High density & Eco - friendly CFC Free Insulation
- Eco - Friendly refrigerant - R134a
- Durable Gasket with easy replacement & Cleaning
- 3" Insulated beer tower
- Door locks
- Recessed door handle
- Simple plug - in

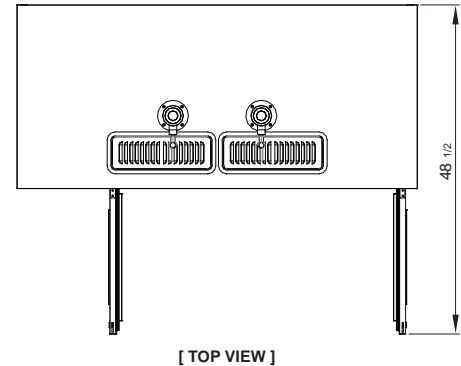
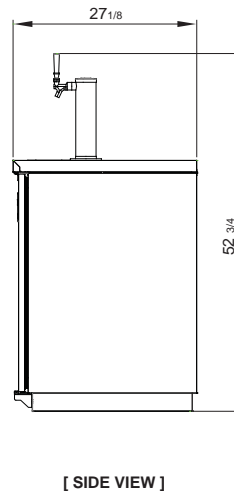
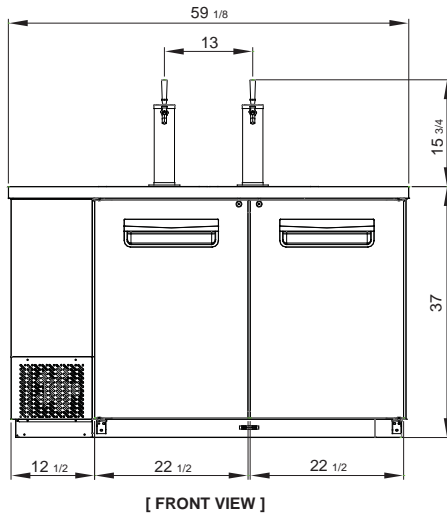

### WARRANTY

- 2 Years Parts and Labor, 5 Years on Compressor in USA



## BLUE AIR Commercial Refrigeration Inc.

223 W. Rosecrans Ave.  
Gardena, CA. 90248 USA

Tel : 1.866.677.8500 / 310.808.0102  
Fax : 310.808.0242 / 310.808.0262

<http://www.Blueairinc.com>  
Email : [info@blueairinc.com](mailto:info@blueairinc.com)