



**BLUE AIR Commercial  
Refrigeration Inc.**



**COMMERCIAL HEAVY DUTY  
MEAT GRINDER**

**BMG 480**



Conforms to NSF/ANSI7\*(ETL)

223 W. Rosecrans Ave. Gardena, CA. 90248 USA

Tel : 1.866.677.8500 / 310.808.0102  
Fax : 310.808.0242 / 310.808.0262



## BMG 480 Commercial Heavy Duty Meat Grinder

### Product Specification

MODEL NAME	BMG 480
Product Description	Meat Grinder
Exterior Dimensions(WxDxH)	10 1/2" x 18" x 18"
Net Weight(lbs)	51
Input Power	AC 110 ~ 120V / 60Hz
Motor	1 HP / 735 W

\* BLUE AIR has the right to change specifications without further notice.

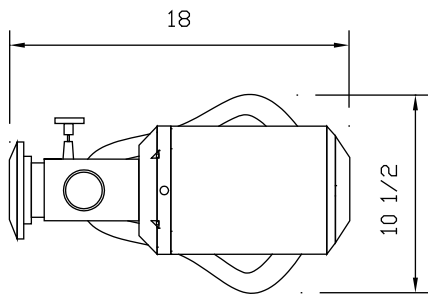

[ TOP VIEW ]

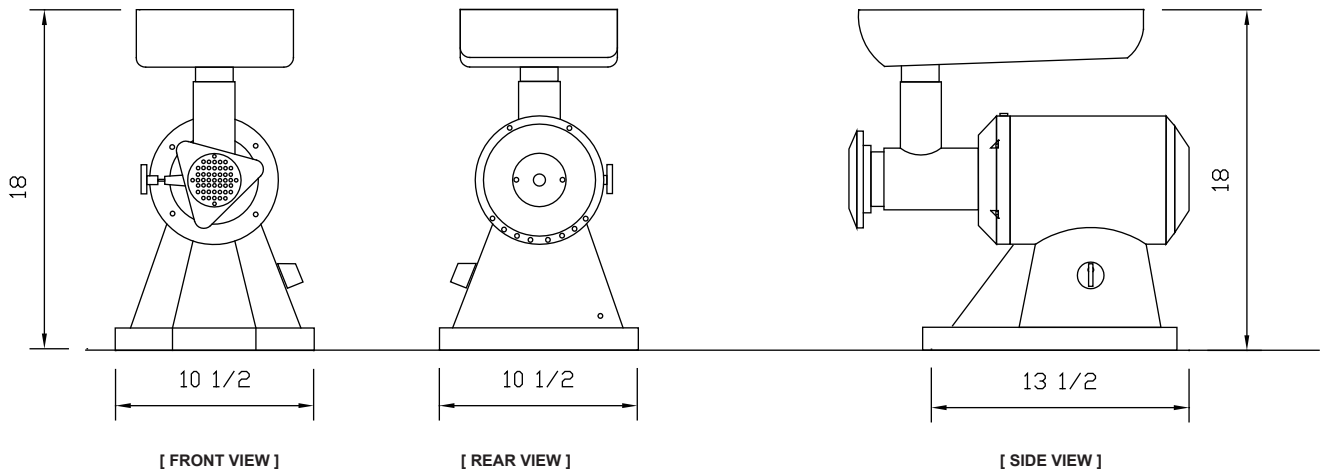

● **GEAR POWERED SCREW MOTOR.**

Our Heavy Duty Bull Grinder includes a powerful 1Hp to provide you with maintenance free. This provides you with the essential function to grind meat at a swift pace without crushing or mashing the product.

● **THE HIGH QUALITY STAINLESS STEEL SURFACES.**

Meat product will only contact the high quality stainless steel surfaces to ensure cleanliness as well as safety.

● **EASILY REMOVED AND CLEANED.**

The bowl assembly and feeding tray can be easily removed and cleaned without the inconvenience of using tools.

● **SAFETY OPENING FUNCTION.**

The stainless steel bowl assembly also includes a safety opening function to decrease the possibility of acquiring any injuries to the user.

● **CONFORMS TO ALL SAFETY REGULATIONS.**

● **THE REVERSE SWITCH.**

Another ideal advantage is the reverse switch. This special feature is intended to maximize productivity by reducing operator fatigue and discomfort.

● **OTHER IMPORTANT BENEFITS.**

Bull Grinder provides superior performance to handle most tough meat and food grinding jobs. Also this heavy-duty machine grinds up to 9 to 14 lbs per minute.

### WARRANTY

- 12 Months Parts and Labor in USA

