



BLUE AIR Commercial Refrigeration Inc.

SINKS Stainless Steel Commercial 2 Compartment Sinks

Product Specification

MODEL NAME	PRODUCT	OUT SIDE(W x D x H)	BOWL SIDE(W x D x H)	WEIGHT (lbs)
BS2-18/N	2 Compartment No Drain Board	42" x 24" x 44 1/2"	18" x 18" x 11"	47
BS2-18/R	2 Compartment 1 Right Drain Board	57" x 24" x 44 1/2"	18" x 18" x 11"	61
BS2-18/L	2 Compartment 1 Left Drain Board	57" x 24" x 44 1/2"	18" x 18" x 11"	61
BS2-18/2D	2 Compartment 2 Drain Board	72" x 24" x 44 1/2"	18" x 18" x 11"	70

* BLUE AIR has the right to change specifications without further notice.

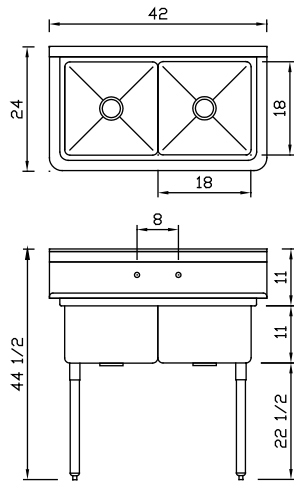
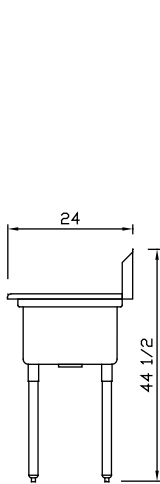

[BS2-18/N]

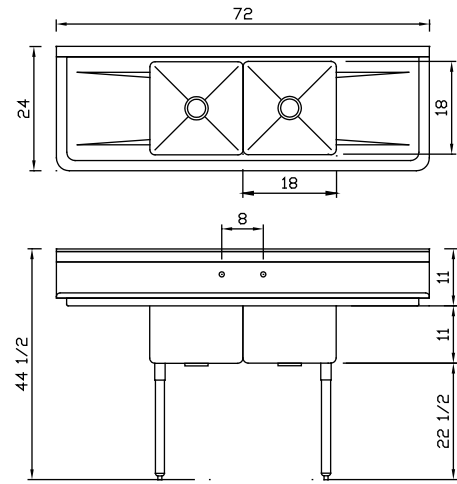

[BS2-18/2D]

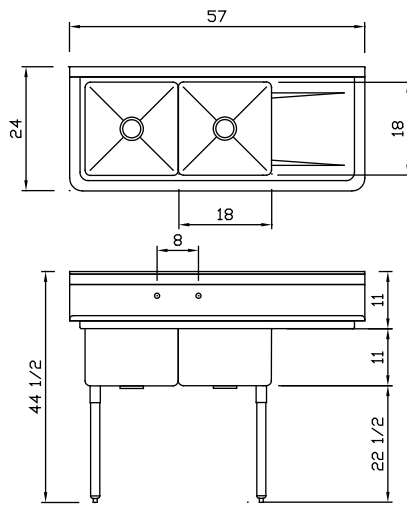
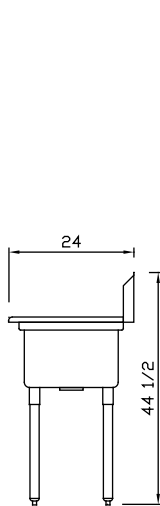

[BS2-18R]

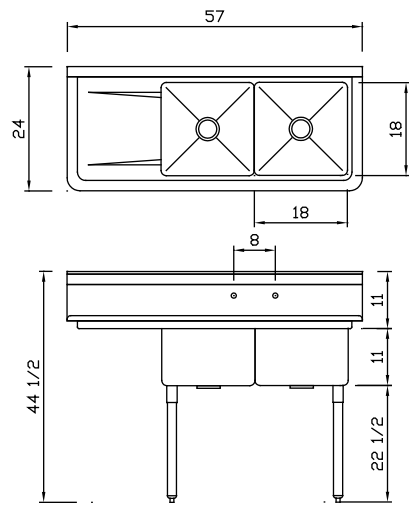

[BS2-18/L]



BLUE AIR Commercial Refrigeration Inc.

223 W. Rosecrans Ave.
Gardena, CA. 90248 USA

Tel : 1.866.677.8500 / 310.808.0102
Fax : 310.808.0242 / 310.808.0262

<http://www.Blueairinc.com>
Email : info@blueairinc.com