



BLUE AIR Commercial Refrigeration Inc.

[D-Series]

Reach-In Solid Swing Door Refrigerator

BSR49



WARRANTY

- 18 Months Parts and Labor, 5 Years on Compressor in USA



Conforms to NSF/ANSI 7(ETL)

223 W. Rosecrans Ave. Gardena, CA. 90248 USA

Tel : 1.866.677.8500 / 310.808.0102
Fax : 310.808.0242 / 310.808.0262



BSR49 Bottom Mount Reach-In Solid Swing Door Refrigerator

D-Series

Product Specification

MODEL NAME	BSR49
Product Description	Refrigerator
Capacity(Cu.ft.)	49
Exterior Dimensions(WxDxH)	54" x 31" x 82 3/8"
Net Weight(lbs)	370
Foot	Caster 4
Door Type	2 Doors (Swing)
Door Auto Closer	Equipped
Shelves	8 ea
Input	AC 115V / 60Hz
Amps	7.0 A
Compressor(Hp)	1/3 HP
Refrigerant	R-134a
Range of Temperature	28~39 °F

* BLUE AIR has the right to change specifications without further notice.

- Bottom Mounted Refrigeration System.
- Stainless Steel Interior and Exterior.
- Oversized Refrigeration System
- Digital Temperature controller
- Self-Closing & Stay Open Door.
- Recessed Handles.
- Refrigeration system is optimized to function at 32~40F.
- Air Guard on rear wall ensuring proper air flow and cooling.
- Evaporator fan stop when door opens.
- Incandescent light interior.
- 5" Diameter swivel casters with front brakes.
- Energy Star rated.
- High Density Cell Polyurethane Insulation (CFC free).
- Accommodates full size bun sheet pans.
- 4 Shelves per door section.
- 1" adjustable shelving heights.
- Door open warming Alarm.
- Door locks - each door is equipped with individual locks
- Durable usage door gasket
- Fabric condensation Kit
- Elegant Round Corners
- Conforms to NSF/ANSI 7(ETL)

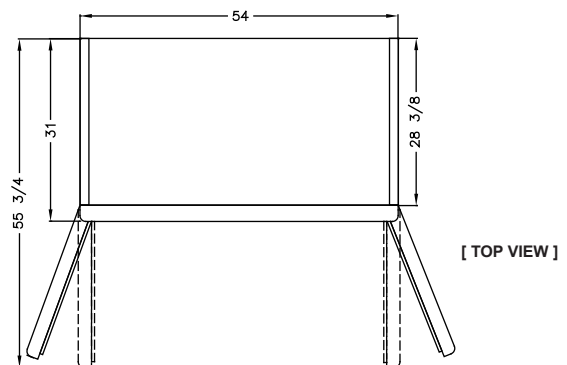
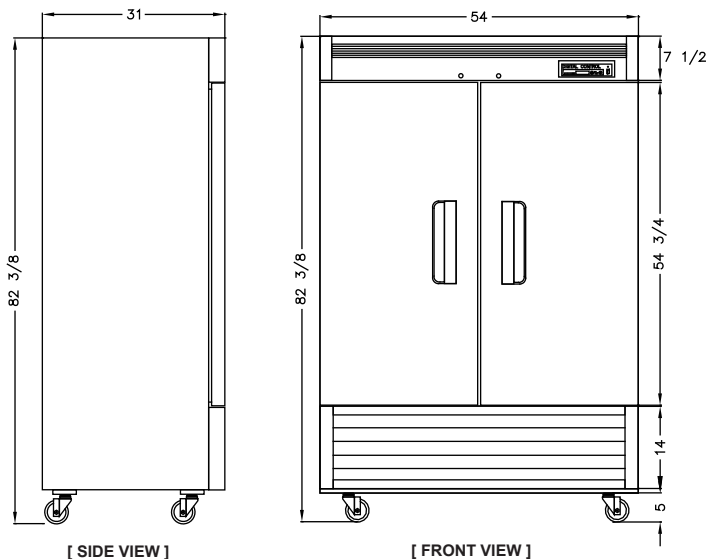

WARRANTY

- 18 Months Parts and Labor, 5 Years on Compressor in USA



BLUE AIR Commercial Refrigeration Inc.

223 W. Rosecrans Ave.
Gardena, CA. 90248 USA

Tel : 1.866.677.8500 / 310.808.0102
Fax : 310.808.0242 / 310.808.0262

<http://www.Blueairinc.com>
Email : info@blueairinc.com