



BLUE AIR Commercial Refrigeration Inc.

[D-Series]

Reach-In Solid Swing Door Refrigerator

BSR49T



WARRANTY

- 18 Months Parts and Labor, 5 Years on Compressor in USA



Conforms to NSF/ANSI 7(ETL)

223 W. Rosecrans Ave. Gardena, CA. 90248 USA

Tel : 1.866.677.8500 / 310.808.0102

Fax : 310.808.0242 / 310.808.0262



BSR49T Top Mount Reach-In Solid Swing Door Refrigerator

D-Series

Product Specification

MODEL NAME	BSR49T
Product Description	Refrigerator
Capacity(Cu.ft.)	49
Exterior Dimensions(WxDxH)	54" x 31" x 82 3/8"
Net Weight(lbs)	348 lbs
Foot	Caster 4
Door Type	2 Doors (Swing)
Door Stopper	Equipped (105°)
Shelves	8 ea
Input	AC 115V / 60Hz
Amps	5.1 A
Compressor(Hp)	1/3 HP
Refrigerant	R-134a
Range of Temperature	28~39°F
Easy to Service	Sliding Condensing Unit

* BLUE AIR has the right to change specifications without further notice.

- 5" Diameter Swivel Casters with front brakes
- Door open Warning Alarm
- Elegant Round Corners
- Durable Usage door Gasket
- Conforms to NSF/ANSI 7(ETL)

- Top Mounted Refrigeration System.
- Stainless Steel Interior and Exterior.
The excellent quality of stainless steel helps minimize dents, scratches, and rust. In addition, our stainless steel offers long-life durability and easy maintenance.
- Defrost Water Evaporation fan system
- Digital Temperature controller
Easy to operate & Perform problem shooting.
- Self-Closing & Stay Open Door.
- Recessed Handles.
Our patented smooth and elegant door handles prevent shipping damage and handle breakage.
- High Density Cell Polyurethane Insulation (CFC free).
CFC free and high density cell foam is used to ensure environment-friendliness and greater energy efficiency.
- Round Corner
- Door Locks - each door is equipped with individual locks
- Air Guard - Enable to ensure proper air flow and cooling
- In Candescent light interior

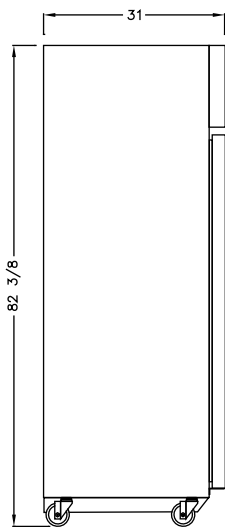

[SIDE VIEW]

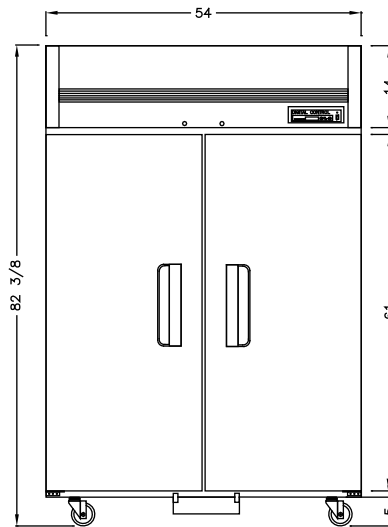

[FRONT VIEW]

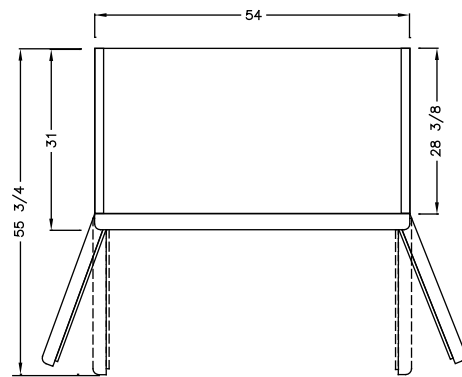

[TOP VIEW]

WARRANTY

- 18 Months Parts and Labor, 5 Years on Compressor in USA

