



COMMERCIAL REFRIGERATION

223 W. Rosecrans Ave., Gardena, CA 90248

Toll Free 1.866.677.8500 T. 310.808.0102, F.310.808.0242

www.blueairinc.com | info@blueairinc.com

PROJECT :	
MODEL # :	
ITEM # :	QTY :
AVAILABLE W/H :	
APPROVAL :	

Work Tables / Equipment Stands / Wall Shelves

High Quality 430 Stainless steel



STANDARD FEATURES

HIGH POLISHED 430 SERIES STAINLESS STEEL TOP

16 GAUGE HEAVY DUTY STAINLESS STEEL TOP(EQUIPMENT STAND)

GALVANIZED STEEL UNDER SHELF & LEGS WITH BULLET FEET (EQUIPMENT STANDS & WORK TABLES)

ADJUSTABLE UNDER SHELF

STAINLESS STEEL LEGS AVAILABLE (OPTIONAL)



Conforms to NSF/ANSI 2

APPROVALS:

AVAILABLE AT:

Work Tables / Equipment Stands / Wall Shelves

PRODUCT SPECIFICATION

Commercial Work Tables

NAME	DIMENSION(WxLxH)	WEIGHT(lbs)
EW2424	24" x 24" x 34"	40
EW2430	24" x 30" x 34"	46
EW2436	24" x 36" x 34"	51
EW2448	24" x 48" x 34"	62
EW2460	24" x 60" x 34"	73
EW2472	24" x 72" x 34"	82
EW2496	24" x 96" x 34"	104
EW3030	30" x 30" x 34"	52
EW3036	30" x 36" x 34"	60
EW3048	30" x 48" x 34"	69
EW3060	30" x 60" x 34"	81
EW3072	30" x 72" x 34"	92
EW3096	30" x 96" x 34"	115

* BLUE AIR has the right to change specifications without further notice.

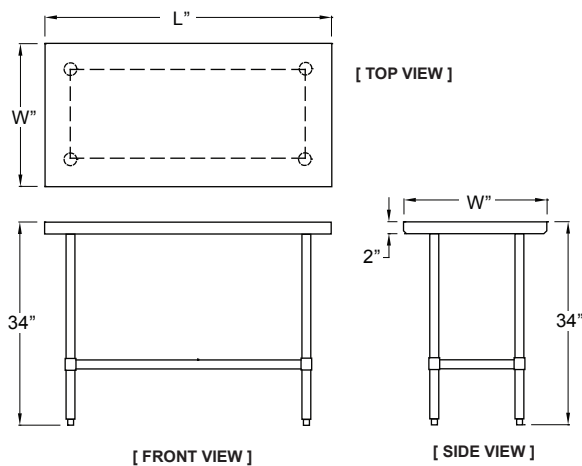

STANDARD FEATURES

- Stainless steel 430 series
- High polished stainless steel top (Work Tables & Equipment Stand)
- Galvanized steel undershelf and galvanized steel legs with bullet feet (Work Tables & Equipment Stand)
- Adjustable undershelf
- 16 Gauge heavy duty Equipment Stand
- Stainless steel legs available(Optional)

Heavy Duty Equipment Stands

NAME	DIMENSION(WxLxH)	WEIGHT(lbs)
ES3012	30" x 12" x 27 3/4"	34
ES3024	30" x 24" x 27 3/4"	41
ES3036	30" x 36" x 27 3/4"	57
ES3048	30" x 48" x 27 3/4"	70
ES3060	30" x 60" x 27 3/4"	83
ES3072	30" x 72" x 27 3/4"	96

* BLUE AIR has the right to change specifications without further notice.

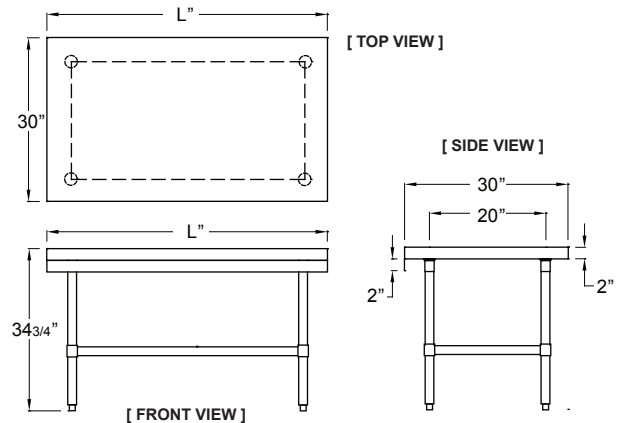

Commercial Wall Shelves

NAME	DIMENSION(WxLxH)	WEIGHT(lbs)	REMARK
WS1224	12" x 24"	12	2 Brackets
WS1236	12" x 36"	15	2 Brackets
WS1248	12" x 48"	18	2 Brackets
WS1260	12" x 60"	20	2 Brackets
WS1272	12" x 72"	24	3 Brackets
WS1296	12" x 96"	30	3 Brackets
WS1424	14" x 24"	14	2 Brackets
WS1436	14" x 36"	17	2 Brackets
WS1448	14" x 48"	20	2 Brackets
WS1460	14" x 60"	25	2 Brackets
WS1472	14" x 72"	28	3 Brackets
WS1496	14" x 96"	36	3 Brackets

* BLUE AIR has the right to change specifications without further notice.

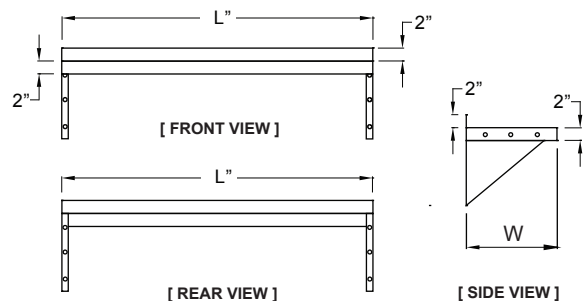

223 W. Rosecrans Ave., Gardena, CA 90248
Toll Free 1.866.677.8500 T. 310.808.0102, F. 310.808.0242

www.blueairinc.com | info@blueairinc.com