



HEAVY DUTY ELECTRIC FRYER

Job _____ Item # _____

ELECTRIC COUNTERTOP FRYER

Model – BPHEF30Ti



Model BPHEF30Ti

SPECIFICATIONS

Electric Fryer fits in tight counter space and is available in 15lb capacity

Reaches frying temperature fast, and maintains heat levels from one load to next

Cooks 30lbs of potatoes in 1 hour

Cycling light alerts operator that unit is ready for next batch of fries

Unit automatically shuts down if frying compound overheats

Stainless steel exterior is easy to wipe clean

WARRANTY

Baker's Pride cooking equipment is backed by a 1-year limited warranty, and a 1-year onsite labor warranty.

STANDARD FEATURES

- Stainless steel construction
- 4" (10 cm) legs
- Front panel permits easy servicing
- Lift-out, one piece tank with carrying handles, Large foaming area above frying compound level
- Insulating air pocket surrounds tank for improved temperature control
- Swing up, pyrolytic heating elements with two-stage locking mechanism
- Cold-zone under heating elements reduces circulation of particles in frying compound
- Front-located adjustable thermostat (200°F/93°C to 400°F/204°C) with on/off switch
- High-limit protection control circuit breaker which automatically trips should frying compound overheat.
- High temperature 392°F (200°) internal wiring
- Nickel-plated twin fry baskets with front hangers

CERTIFICATIONS



BAKER'S PRIDE OVEN COMPANY, INC.
1307 N. Watters Rd. Suite 180
Allen, TX 75013
(972) 908-6100 (800) 431-2745 fax (214) 576-0605
www.bakerspride.com

Continuous product improvement is a policy of Baker's Pride Oven Company. Therefore, specifications and design are subject to change without notification.



HEAVY DUTY ELECTRIC FRYER

Job _____ Item # _____

ELECTRIC COUNTERTOP FRYER

PRODUCT SPECIFICATIONS

Construction:

Heavy-duty stainless steel body. Fry baskets are constructed of nickel-plated steel. 4" adjustable chrome legs.

Electrical Information

Units are wired for hard wiring in the field

Electrical Specifications

BPHEF-30Ti 208/240V, 5.74/4.48W, 23.8/20.6A

Capacity

BPHEF-30Ti 30lbs (13.6kg)

Basket Size

4 half size 6.9" x 3.5" x 11.4"

Or

2 full size

Overall Dimensions

BPHEF-30Ti

Shipping

BPHEF-30Ti: lb (kg)

Freight Class: 85

FOB: Standex Dock

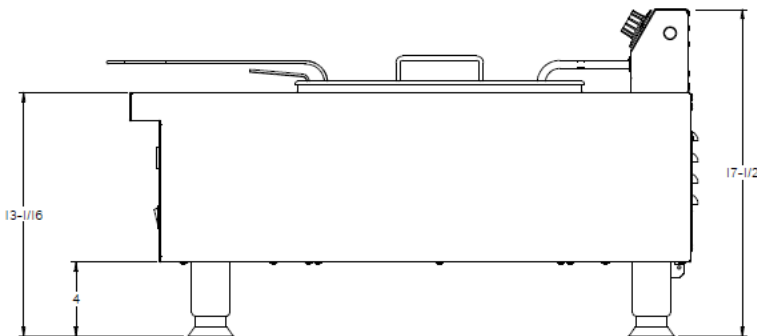
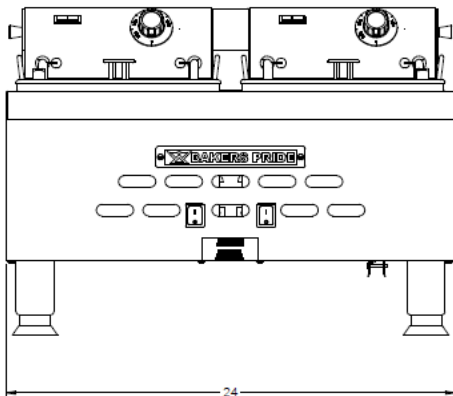
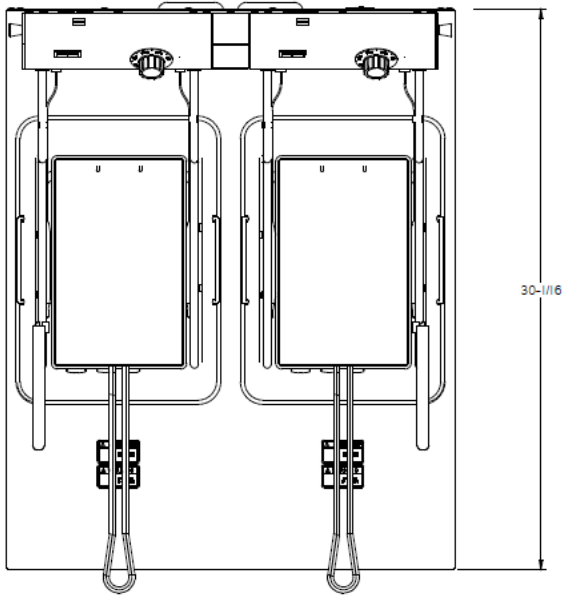

BAKER'S PRIDE OVEN COMPANY, INC.
1307 N. Watters Rd. Suite 180
Allen, TX 75013
(972) 908-6100 (800) 431-2745 fax (214) 576-0605
www.bakerspride.com

Continuous product improvement is a policy of Baker's Pride Oven Company. Therefore, specifications and design are subject to change without notification.