



Item No. _____

12qt PLANETARY MIXER BMPM012

Features:

- Gear driven.
- Professional countertop style.
- ½ HP motor offers enough power to mix stiffer dough and larger batches.
- All metal and die-cast aluminum body.
- Transmission is made of hardened alloy steel gears.
- All shafts are mounted in ball bearings.
- Automatic electronic 3 speed control.
- Planetary mixing action ensures perfect results.
- Simple hand lift for tool change and bowl removal.

Other specifications:

- 12qt stainless steel bowl.
- 30 Minute digital timer.
- Includes dough hook, flat beater and wire whip.
- Safety guard is standard for model BMPM007 and provides with automatic shut-off when guard is opened at any speed.
- Plug N' Go electrical for easy installation.



BakeMax[®] Planetary Mixers provide durability, long life and excellent mixing performance. A wide range of sizes to choose from provides clients with the exact mixer for their particular needs. They are safe, easy to use and capable of a broad range of dough and food mixing applications.

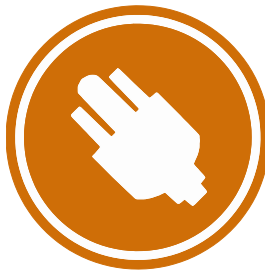

Think Quality, Value, Service.....Think

BakeMax[®]

12qt PLANETARY MIXER BMPM012

Volume

External and Internal Dimensions (D x W x H)

Model	External
BMPM012	19" x 14.5" x 25.5"

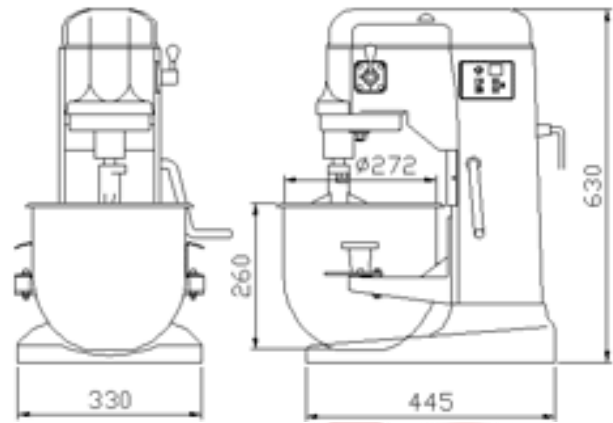
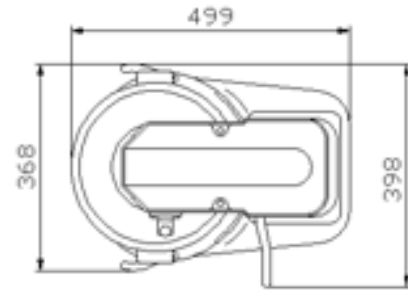

Electrical Information

Model	Voltage	Phase	Amps	Watts	Hertz	NEMA
BMPM012	110	1	8	880	60	5



Authorized Dealer:



BakeMax Manufacturing, Inc.
170 Millenium Blvd, Moncton, NB, E1C 1M8
Toll Free: 1-800-565-BAKE
Telephone: 1-506-858-8990
Fax: 1-506-859-6929

Think Quality, Value, Service.....Think

BakeMax[®]

Toll Free: 1-800-565-BAKE

Web Site: www.bakemax.com

E-mail: sales@bakemax.com

Printed in Canada