



BEVERAGE-AIR

3779 Champion Blvd., Winston-Salem, NC 27105
1-888-845-9800 Fax# 1-336-245-6453
<http://www.Beverage-Air.com>

Commercial Refrigeration Equipment General Specification

3 Year Parts/Labor Warranty Additional 2 Year Compressor Warranty

BM23-S-31—BARMOBILE BEER DISPENSER

The BM23-S-31 provides outdoor mobility with a variety of applications (home, club, hospitality). With full keg capacity and heavy-duty, forced air refrigeration, beer is dispensed ice cold every time.

CABINET CONSTRUCTION

Standard construction includes complete stainless steel exterior.

Top is made of heavy-duty stainless steel including drip dray for easy cleaning. Four-inch (4") heavy-duty swivel casters are standard.

Three-inch (3") insulated tower with single faucet is included with the BM23. Tower is adapted to have a continuous source of cold air channeled into it to keep beer at its coldest, best quality when dispensed.

Inside construction utilizes galvanized steel for walls and ceiling. Reinforced floors and doorsill are made from heavy-duty stainless steel to provide lasting service. Door lock standard. Magnetic gasket provides positive door sealing.

Cabinet insulation is foamed-in-place polyurethane (CFC-free) which helps to provide maximum operating efficiency and strength in the overall construction.

Includes beer waste bottle to capture beer from drain.

REFRIGERATION

CFC-free R134a refrigerant used in Barmobiles to comply with all environmental concerns.

ELECTRICAL

Units wired at factory and ready for connection to a 115/60/1 phase, 15 amp dedicated outlet. 8' long cord and plug set included.

SPECIAL FEATURES

- UL Listed for Outdoor Use
- Beer waste bottle to capture beer from drain

Item No. _____
Quantity _____

**DRAFT BEER
EQUIPMENT BARMOBILE
PORTABLE DRAFT BEER
DISPENSERS
BM SERIES—OUTDOOR USE**

**MODELS:
BM23-S-31**



BM23-S-31

***Note:** Overall heights of casters may vary with different types of casters depending upon caster manufacturer designations.

Available From:



Model Specified _____

Store# _____

Location _____

Quantity _____



BEVERAGE-AIR

Barmobile

Models: **BM23-S-31**

MODEL	BM23-S-31
EXTERNAL DIMENSIONAL DATA	
Length Overall (inches)	24"
Length Overall (mm)	610
Depth Overall (inches)	29 1/2"
Depth Overall (mm)	749
Height Overall— on casters (inches)*	39"
Height Overall—on casters (mm)*	991
Clear Door Opening (inches)	14 5/8" x 8
Depth With Door Open 90°	48"
Number of doors	1
INTERNAL DIMENSIONAL DATA	
NET Capacity (cubic ft.)	7.8
NET Capacity (Liters)	221
Internal Length Overall (inches)	19"
Internal Length Overall (mm)	483
Internal Depth Overall (inches)	23 3/4"
Internal Depth Overall (mm)	603
Internal Height Overall (inches)	29 1/2"
Internal Height Overall (mm)	749
Number of Kegs (straight wall)	1
ELECTRICAL DATA	
Full Load Amperes 115/60/1	4
ENERGY CONSUMPTION (KWH)	
	1.85
REFRIGERATION DATA	
Horsepower	1/5
WEIGHT DATA	
Gross Weight (Crated lbs)	184
Gross Weight (Crated kg)	84

***Note:** Overall heights of casters may vary with different types of casters depending upon caster manufacturer designations.

PLAN VIEWS

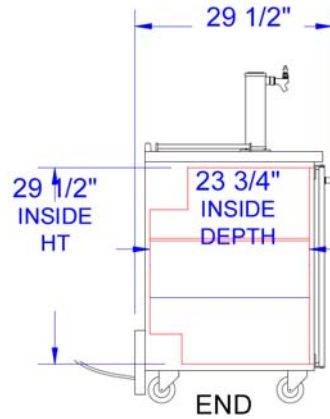

COMMON END VIEW

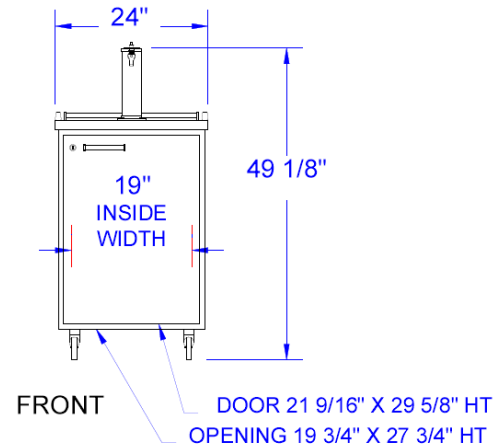

BM23 FRONT

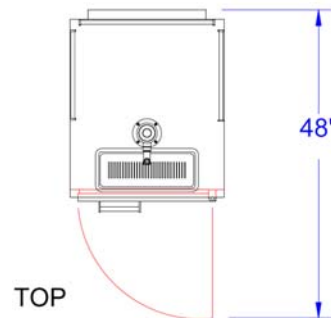

BM23 TOP



ELECTRICAL CONNECTION

Units pre-wired at factory and include 8' long cord and plug set.



115/60/1
NEMA-5-15P

BEVERAGE-AIR® CORPORATION

3779 Champion Blvd. • Winston-Salem, NC 27105 USA • (336) 245-6400 • Fax (336) 245-6453 • (888) 845-9800 • www.beverage-air.com

Specifications are subject to change without prior notice. 06/13