



# BEVERAGE-AIR

3779 Champion Blvd., Winston-Salem, NC 27105  
1-888-845-9800 Fax# 1-336-245-6453  
<http://www.Beverage-Air.com>

## Commercial Refrigeration Equipment General Specification

### 3 Year Parts/Labor Warranty Additional 2 Year Compressor Warranty

#### DD 23" BASE SERIES—DIRECT DRAW DISPENSERS

Shallow depth, direct draw dispensers come in two widths of 48" and 72." Depth is 23" from face of door to back of cabinet. Handle projects 1/2."

#### CABINET CONSTRUCTION

Standard, cabinet exterior construction includes attractive, wear resistant vinyl on steel in black exterior finish. Top is made from heavy-duty stainless steel including drip tray(s) for easy cleaning.

Doors are self-closing and include key locks. Magnetic gaskets provide positive door sealing.

Standard interior construction utilizes galvanized steel walls and ceiling. Reinforced floor and door sills are made from heavy-duty stainless steel to provide long lasting service.

Foamed-in-place CFC and HCFC-free polyurethane insulation enhances the structural strength of the cabinet and helps increase energy efficiency.

Three-inch (3") insulated towers are provided. Towers are adapted to have a continuous source of cold air channeled into it to keep beer at its coldest, best quality the moment it is dispensed.

Drain tube located at bottom front of cooler for connection to floor drain.

#### REFRIGERATION

Models feature forced air refrigeration to keep beer in kegs ice cold for dispensing. Refrigeration system uses R134a refrigerant, which is CFC and HCFC-free for compliance with environmental safety concerns.

#### ELECTRICAL

Units wired at factory and ready for connection to a 115/60/1 phase, 15 amp dedicated outlet. 8' long cord and plug set included.

#### SPECIAL FEATURES

- Key locks
- Stainless options available
- Drain tube located at bottom front of cooler for connection to floor drain.

Item No. \_\_\_\_\_  
Quantity \_\_\_\_\_

**DRAFT BEER EQUIPMENT  
DIRECT DRAW DISPENSERS  
23" BASE  
DD SERIES**

**MODELS:  
DD48/DD48Y  
DD72/DD72Y**



DD48



DD72



\*Note: Not all markings may apply to all model variations.

Available From:

<b>Model Specified</b> _____	<b>Store#</b> _____
<b>Location</b> _____	<b>Quantity</b> _____



## BEVERAGE-AIR

### Direct Draw Dispensers, 23" Base

Models: DD48, DD48Y, DD72, DD72Y

MODEL	DD48	DD48Y	DD72	DD72Y
<b>EXTERNAL DIMENSIONAL DATA</b>				
Length Overall (inches)	48"	48"	72"	72"
Length Overall (mm)	1219	1219	1829	1829
Depth Overall (inches)	23 1/2"	23 1/2"	23 1/2"	23 1/2"
Depth Overall (mm)	597	597	597	597
Height Overall— (inches)	36"	36"	36"	36"
Height Overall— (mm)	914	914	914	914
Clear Door Width (inches)	16 7/16" x 29 1/4"	16 7/16" x 29 1/4"	16 7/16" x 29 1/4"	16 7/16" x 29 1/4"
Depth With Door Open 90°	42 3/4"	42 3/4"	42 3/4"	42 3/4"
Number of doors	2	2	3	3
<b>INTERNAL DIMENSIONAL DATA</b>				
NET Capacity (cubic ft.)	12.1	12.1	19.4	19.4
NET Capacity (Liters)	343	343	549	549
Internal Length Overall (inches)	36"	36"	60"	60"
Internal Length Overall (mm)	914	914	1524	1524
Internal Depth Overall (inches)	18 1/2"	18 1/2"	18 1/2"	18 1/2"
Internal Depth Overall (mm)	470	470	470	470
Internal Height Overall (inches)	29 1/2"	29 1/2"	29 1/2"	29 1/2"
Internal Height Overall (mm)	749	749	749	749
Number of Kegs (straight wall)	2	2	3	3
<b>ELECTRICAL DATA</b>				
Full Load Amperes 115/60/1	6	5	6	5
<b>ENERGY CONSUMPTION (KWH)</b>				
	4.06	3.19	4.36	3.67
<b>REFRIGERATION DATA</b>				
Horsepower	1/4	1/4	1/4	1/4
<b>WEIGHT DATA</b>				
Gross Weight (Crated lbs)	314	314	377	377
Gross Weight (Crated kg)	142	142	171	171

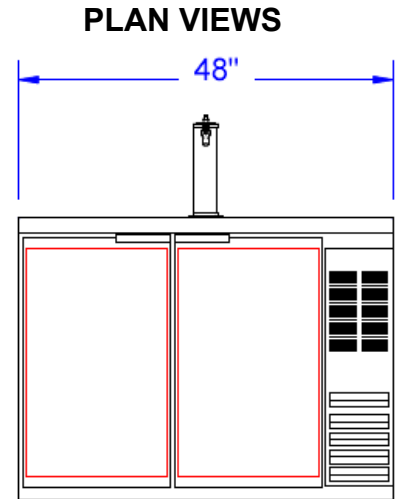

**FRONT**  
**DD48**

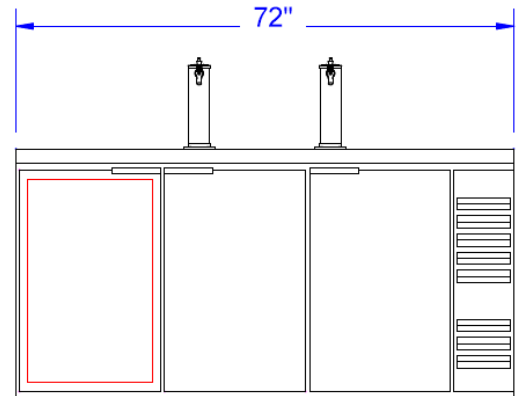

**FRONT**  
**DD72**

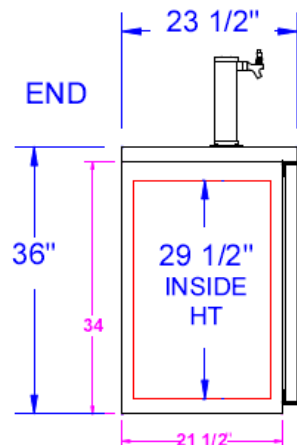

**COMMON END VIEW**



\*Note: Not all markings may apply to all model variations.

### ELECTRICAL CONNECTION

Units pre-wired at factory and include 8' long cord and plug set.



115/60/1  
NEMA-5-15P

## BEVERAGE-AIR® CORPORATION

3779 Champion Blvd. • Winston-Salem, NC 27105 USA • (336) 245-6400 • Fax (336) 245-6453 • (888) 845-9800 • www.beverage-air.com

Specifications are subject to change without prior notice. 04/13