



BEVERAGE-AIR

3779 Champion Blvd., Winston-Salem, NC 27105
1-888-845-9800 Fax# 1-336-245-6453
<http://www.Beverage-Air.com>

CUSTOMER'S CHOICE FOR A HOT KITCHEN
Tested & Certified to Ambient Class of 100°F

3 Year Parts/Labor Warranty Additional 2 Year Compressor Warranty

CABINET CONSTRUCTION

- Exterior—Stainless steel exterior standard,
- Interior - Heavy duty construction includes white coated steel interior walls
- Insulation—foamed-in-place CFC and HCFC-free polyurethane insulation.
- One-piece grille allows easy removal/installation for preventative maintenance.

REFRIGERATION SYSTEM

- Bottom mount balanced refrigeration system for better ergonomics.
- Automatic condensate evaporation system for energy efficiency.
- Forced-air system ensures uniform distribution of airflow throughout the entire cabinet for even product temperatures; maintains product temperatures at 0°F.
- Self-contained refrigeration system uses environmentally friendly (CFC and HCFC-free) R404A refrigerant.

DOOR

- Solid door
- Anti-microbial door handle
- Spring-loaded hinges standard. Positive seal self-closing door with 120° stay open feature.
- Plug-in magnetic door gaskets of one piece construction, removable without tools for ease of cleaning.

SHELVING

- Three (3) heavy duty epoxy coated wire shelves standard. Four (4) shelf clips included per shelf (field installed).
- Shelves are adjustable in ½" increments.

MODEL FEATURES

- Incandescent interior lighting
- 6" heavy-duty casters included, two with brakes standard. 3" casters or 6" legs optional.
- Pre-wired plug for 115/60/1 phase.
- Epoxy coated evaporator prevents corrosion.
- UL-EPH and CUL for open food product.

Item No. _____
Quantity _____

BOTTOM MOUNTED REACH-IN FREEZERS

Horizon Series
Solid Doors

MODEL:
HBF12-1



HBF12-1

Available From:



*Note: Not all markings may apply to all model variations.

Model Specified _____	Store# _____
Location _____	Quantity _____



Horizon Bottom Mount Refrigerators
Models: HBF12-1

MODEL	HBF12-1
EXTERNAL DIMENSIONAL DATA	
Length Overall (inches) Length Overall (mm)	24" 610
Depth Overall (inches) - <i>includes handle</i> Depth Overall (mm) - <i>includes handle</i>	24" 610
Height Overall— (inches) / (mm) <i>Add 6" for legs or casters</i>	62" 1575
Number of doors	1
Depth with Door Open 90°	48.1"
INTERNAL DIMENSIONAL DATA	
NET Capacity (cubic ft.) NET Capacity (Liters)	12 340
Internal Length Overall (inches) Internal Length Overall (mm)	21" 533
Internal Depth Overall (inches) Internal Depth Overall (mm)	20 3/4" 527
Internal Height Overall—(inches) Internal Height Overall—(mm)	45 3/4" 1162
Number of shelves	4
ELECTRICAL DATA	
Full Load Amperes 115/60/1	8.6
REFRIGERATION DATA	
Horsepower	1/3
WEIGHT DATA	
Gross Weight (Crated lbs)	230
Gross Weight (Crated kg)	104

PLAN VIEWS

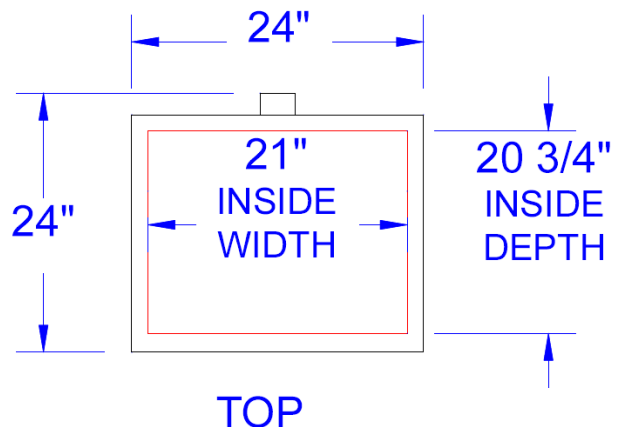
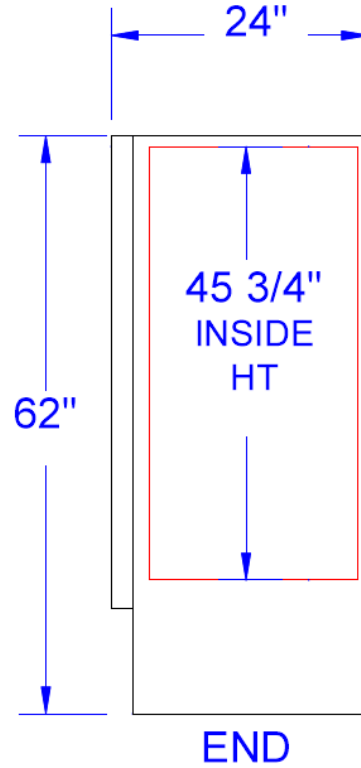

Note: Not all markings may apply to all model variations.

BEVERAGE-AIR® CORPORATION

3779 Champion Blvd. • Winston-Salem, NC 27105 USA • (336) 245-6400 • Fax (336) 245-6453 • (888) 845-9800 • www.beverage-air.com

Specifications are subject to change without prior notice. 07/14