



# BEVERAGE-AIR

3779 Champion Blvd., Winston-Salem, NC 27105  
1-888-845-9800 Fax# 1-336-245-6453  
<http://www.Beverage-Air.com>

**CUSTOMER'S CHOICE FOR A HOT LOCATION**  
**Tested & Certified to Ambient Class of 100°F**

**3 Year Parts/Labor Warranty**  
**Additional 2 Year Compressor Warranty**

## LUMAVUE SERIES—GLASS DOOR MERCHANDISER

Used for merchandising and storage of product.

### CABINET CONSTRUCTION

Heavy duty construction includes white coated steel interior walls. Exterior finish is heavy-duty steel with a baked on durable coating. Choose from black or white finish.

Foamed-in-place CFC and HCFC-free polyurethane insulation enhances the structural strength of the cabinet and helps increase energy efficiency.

Modern, one-piece grille is easily removed for cleaning and servicing.

Double pane, lowE argon filled glass door features inside and outside panes that are tempered for added safety.

Self-closing, hinged glass door features recessed, pocket door handle provides low profile and is more aesthetically pleasing. Door provides automatic hold-open feature.

Five white epoxy coated steel shelves are standard.

Brightly lighted sign panel.

### REFRIGERATION

Whisper-quiet refrigeration system uses R134a refrigerant, which is CFC and HCFC-free for compliance with environmental safety concerns.

Product temperatures from 32°F to 40°F.

### ELECTRICAL

Standard LED lighting provides hidden light source for increased product visibility. LED bulbs last up to 10 times longer compared to fluorescent bulbs and renders additional energy savings due to reduced wattage load on compressor.

Units wired at factory and ready for connection to a 115/60/1

Item No. \_\_\_\_\_  
Quantity \_\_\_\_\_

**HINGED GLASS DOOR**  
**LUMAVUE™**  
**MERCHANDISER SERIES**  
**LV23**

**MODELS:**  
**LV23-1-B-LED**  
**LV23-1-W-LED**



**LV23-1-B (shown with 4 shelves)**

### SPECIAL FEATURES

- LV23 has earned the ENERGY STAR®
- Whisper-quiet refrigeration system
- Recessed, pocket door handle
- Brightly lighted sign panel
- 2010 Federal Energy Compliant
- Gravity Flo kits and Can Roller options available

### ELECTRICAL CONNECTION



115/60/1  
NEMA-5-15P

Units pre-wired at factory and include 8' long cord and plug set.



\*Note: Not all markings may apply to all model variations.

Available From:

Model Specified \_\_\_\_\_

Store# \_\_\_\_\_

Location \_\_\_\_\_

Quantity \_\_\_\_\_



**BEVERAGE-AIR**

**LumaVue Glass Door Merchandisers**

Model: LV23

**PLAN VIEWS**

MODEL	LV23
<b>EXTERNAL DIMENSIONAL DATA</b>	
Length Overall (inches)	27"
Length Overall (mm)	686
Depth Overall (inches)	32"
Depth Overall (mm)	813
Height Overall— (inches)	78"
Height Overall— (mm)	1981
Number of doors	1
Depth with Door Open 90 °	60"
<b>INTERNAL DIMENSIONAL DATA</b>	
NET Capacity (cubic ft.)	23
NET Capacity (Liters)	651
Internal Length Overall (inches)	24"
Internal Length Overall (mm)	610
Internal Depth Overall (inches)	28 1/2"
Internal Depth Overall (mm)	724
Internal Height Overall—(inches)	61 3/4"
Internal Height Overall—(mm)	1569
*Internal Height to Evaporator Housing—(inches)	54"
*Internal Height to Evaporator Housing—(mm)	1372
Number of shelves	5
<b>ELECTRICAL DATA</b>	
Full Load Amperes 115/60/1	5.8 A
<b>REFRIGERATION DATA</b>	
Horsepower	1/3
<b>WEIGHT DATA</b>	
Gross Weight (Crated lbs)	373
Gross Weight (Crated kg)	169

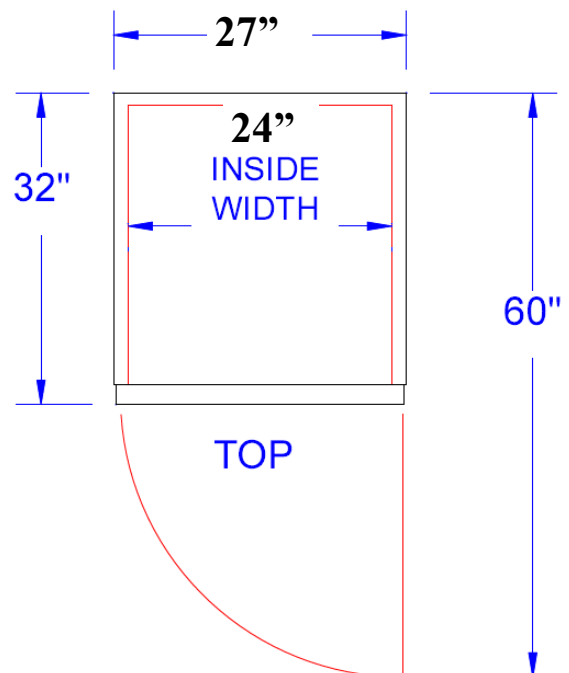
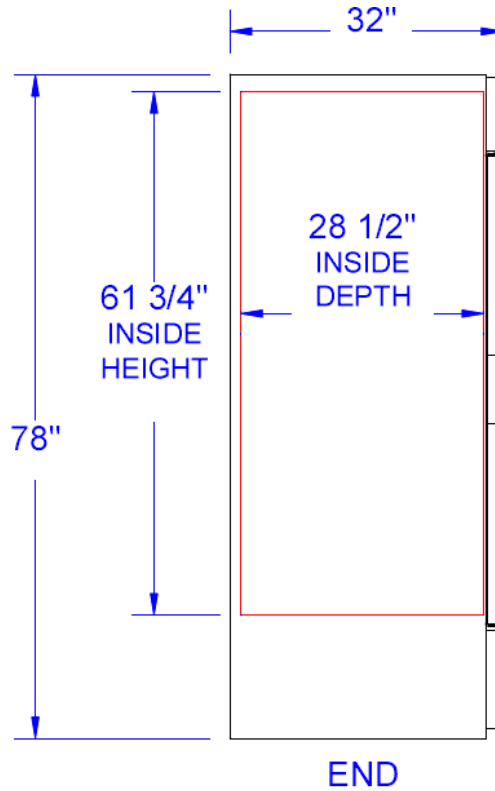

**Note:** Not all markings may apply to all model variations.  
\*Internal height to evaporator housing.

**BEVERAGE-AIR® CORPORATION**

3779 Champion Blvd. • Winston-Salem, NC 27105 USA • (336) 245-6400 • Fax (336) 245-6453 • (888) 845-9800 • www.beverage-air.com

Specifications are subject to change without prior notice. 05/15