



BEVERAGE-AIR

3779 Champion Blvd., Winston-Salem, NC 27105
1-888-845-9800 Fax# 1-336-245-6453
<http://www.Beverage-Air.com>

Commercial Refrigeration Equipment General Specification

3 Year Parts/Labor Warranty Additional 2 Year Compressor Warranty

CURVED FRONT GLASS DOOR MERCHANDISER

Curved front glass door merchandiser is used for merchandising and storage of cold beverages and prepackaged food products.

CABINET CONSTRUCTION

Heavy duty construction includes white coated steel interior walls. Exterior finish is heavy-duty steel with a baked on durable coating. Black exterior finish is standard.

Foamed-in-place CFC and HCFC-free polyurethane insulation enhances the structural strength of the cabinet and helps increase energy efficiency.

Modern, one-piece grille is easily removed for cleaning and servicing.

Triple pane, low E argon filled glass doors feature inside and outside panes that are tempered for added safety.

Self-closing swing doors feature an automatic hold-open feature.

Three white epoxy coated steel shelves are standard.

REFRIGERATION

Refrigeration system uses R134a refrigerant, which is CFC and HCFC-free for compliance with environmental safety concerns.

Product temperatures from 32°F to 40°F.

ELECTRICAL

Interior fluorescent lighting enhances product illumination. Optional LED lighting provides hidden light source for increased product visibility. LED bulbs last up to 10 times longer compared to fluorescent bulbs and renders additional energy savings due to reduced wattage load on compressor.

Units wired at factory and ready for connection to a 115/60/1 phase, 15 amp dedicated outlet. Approximate 8' long cord and plug set included.

Item No. _____
Quantity _____

SWING DOOR MERCHANDISER CURVED FRONT MM14

MODELS:
MM14Y-B-W
MM14Y-B-W-LED



MM14Y-B-W



SPECIAL FEATURES

- Bottom Mount Refrigeration System
- Curved front
- Hinged doors
- Gravity Flo kits and Bev-Trac options available
- Optional LED lighting
- Custom door and side graphics (*contact factory for pricing and artwork requirements*)

ELECTRICAL CONNECTION



115/60/1
NEMA-5-15P

Units pre-wired at factory and include approximate 8' long cord and plug set.

Available From:



*Note: Not all markings may apply to all model variations.

Model Specified _____	Store# _____
Location _____	Quantity _____



BEVERAGE-AIR

**Swing Door Merchandiser
Curved Front**

Model: MM14Y-B-W (black exterior, white interior)

MODEL	MM14Y-B-W
EXTERNAL DIMENSIONAL DATA	
Length Overall (inches)	36"
Length Overall (mm)	914
Depth Overall (inches)	18 1/4"
Depth Overall (mm)	464
Height Overall— (inches)	56"
Height Overall— (mm)	1422
Number of doors	2 hinged doors
INTERNAL DIMENSIONAL DATA	
NET Capacity (cubic ft.)	14
NET Capacity (Liters)	396
Internal Length Overall (inches)	32 1/4"
Internal Length Overall (mm)	819
Internal Depth Overall (inches)	15 3/4"
Internal Depth Overall (mm)	400
Internal Height Overall—(inches)	40 1/2"
Internal Height Overall—(mm)	1029
Number of shelves	3
ELECTRICAL DATA	
Full Load Amperes 115/60/1	5.8 A
REFRIGERATION DATA	
Horsepower	1/3
WEIGHT DATA	
Gross Weight (Crated lbs)	344
Gross Weight (Crated kg)	156

PLAN VIEWS

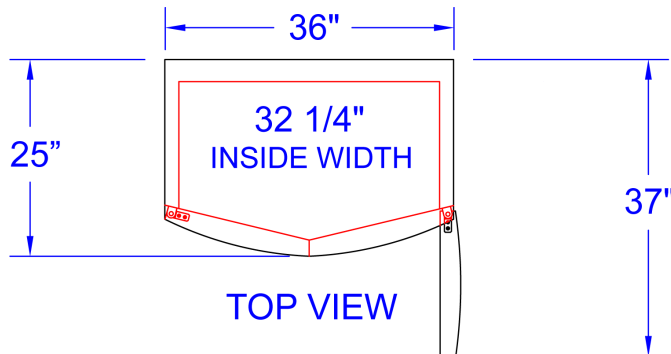
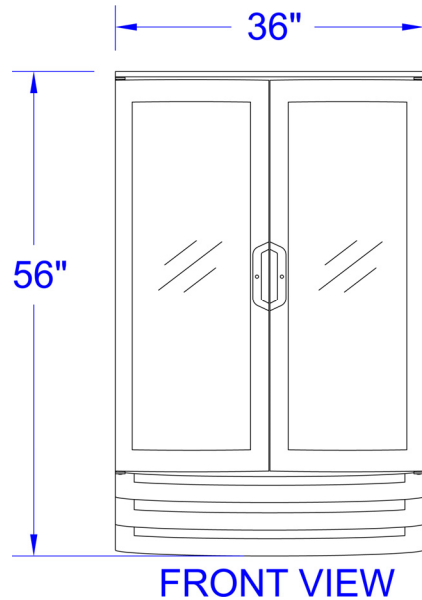
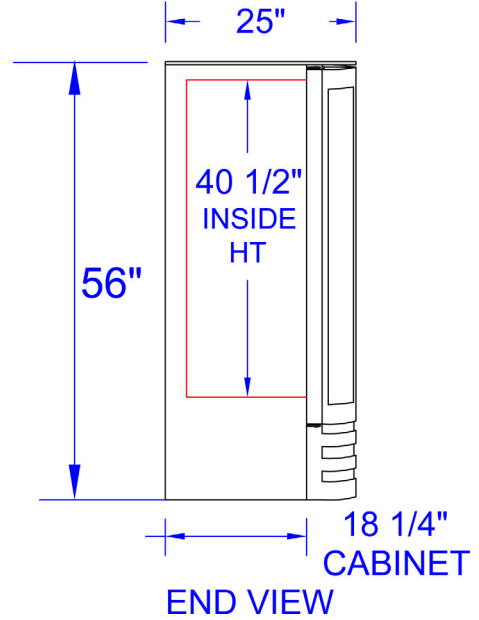

Note: Not all markings may apply to all model variations.

BEVERAGE-AIR® CORPORATION

3779 Champion Blvd. • Winston-Salem, NC 27105 USA • (336) 245-6400 • Fax (336) 245-6453 • (888) 845-9800 • www.beverage-air.com

Specifications are subject to change without prior notice. 04/13