



BEVERAGE-AIR

3779 Champion Blvd., Winston-Salem, NC 27105
1-888-845-9800 Fax# 1-336-245-6453
<http://www.Beverage-Air.com>

CUSTOMER'S CHOICE FOR A HOT LOCATION
Tested & Certified to Ambient Class of 100°F

3 Year Parts/Labor Warranty
Additional 2 Year Compressor Warranty

MARKETMAX™ GLASS DOOR ICE MERCHANDISER

Single section glass door ice merchandiser with lighted sign panel used for merchandising and storage of ice.

CABINET CONSTRUCTION

Heavy duty construction includes white coated steel interior walls. White or black exterior finishes are heavy-duty steel with a baked on durable coating.

Foamed-in-place CFC and HCFC-free polyurethane insulation.
Modern, one-piece grille is easily removed for cleaning and servicing.

Freezer model features heated triple pane glass. Inside and outside panes are tempered for added safety. Anti-microbial door handles are standard. Door provides automatic hold-open feature.

Brightly lighted sign panel.

STORAGE CAPACITY

Raised interior floor rack and backguard prevents bags of ice from blocking proper airflow.

Holds (54) 8 lbs. (4 kg) bags of ice.

ELECTRONIC CONTROL

Electronic thermostat with manual defrost button provides a digital display of cabinet temperatures, which includes status indicators and key pad for any necessary temperature adjustments.

REFRIGERATION

Self-contained bottom mount refrigeration system. Expansion valve refrigerant control on freezer provides quick temperature pull down and reduces compressor run time—meaning reduced energy consumption. Includes automatic condensate disposal. Freezers utilize ozone friendly R404A refrigerant and its defrost system is fully automatic, time-initiated and temperature terminated operation.

Freezer product temperatures from 20°F to 25°F (-6.6°C to -3.8°C).

ELECTRICAL

Interior fluorescent lighting enhances product illumination. Optional LED lighting provides hidden light source for increased product visibility. LED bulbs last up to 10 times longer compared to fluorescent bulbs and renders additional energy savings due to reduced wattage load on compressor.

Freezer units wired at factory and ready for connection to a 115/60/1 phase, 20 amp dedicated outlet. 8' long cord and plug set included.

Item No. _____
Quantity _____

HINGED GLASS DOOR MARKETMAX™ ICE MERCHANDISER SERIES

MMF27 Freezer
Single Door

MODELS:
MMF27-1-B-ICE
MMF27-1-W-ICE
MMF27-1-B-ICE-LED
MMF27-1-W-ICE-LED



MMF27-1-B-ICE
(SHOWN IN BLACK EXTERIOR)
White finish available

SPECIAL FEATURES

- MMF27 has earned the ENERGY STAR®
- Holds (54) 8lbs. (4 kg) bags of ice
- Anti-microbial door handle
- Electronic control with digital display
- Brightly lighted sign panel
- Optional LED lighting
- **Available options:** S/S Exterior, Black Interior, Casters, Audible Alarm With PM Feature, Smart Defrost



115/60/1
NEMA-5-20P
Freezer

ELECTRICAL CONNECTION

Units pre-wired at factory and include 8' long cord and plug set.

Available From:



*Note: Not all markings may apply to all model variations.

Model Specified _____	Store# _____
Location _____	Quantity _____



MarketMax™ Glass Door Ice Merchandisers
Models: MMF27-1-B-ICE, MMF27-1-W-ICE

MODEL	MMF27
EXTERNAL DIMENSIONAL DATA	
Length Overall (inches)	30"
Length Overall (mm)	762
Depth Overall (inches) - includes handle	33 3/4"
Depth Overall (mm) - includes handle	857
Height Overall— (inches)	78"
Height Overall— (mm)	1981
Number of doors	1
Depth with Door Open 90 °	60"
INTERNAL DIMENSIONAL DATA	
NET Capacity (cubic ft.)	27
NET Capacity (Liters)	765
Internal Length Overall (inches)	27"
Internal Length Overall (mm)	686
Internal Depth Overall (inches)	28 1/2"
Internal Depth Overall (mm)	724
Internal Height Overall—(inches)	61 3/4"
Internal Height Overall—(mm)	1569
ELECTRICAL DATA	
Full Load Amperes 115/60/1	13.8 A
REFRIGERATION DATA	
Horsepower	3/4
WEIGHT DATA	
Gross Weight (Crated lbs)	400
Gross Weight (Crated kg)	181

PLAN VIEWS

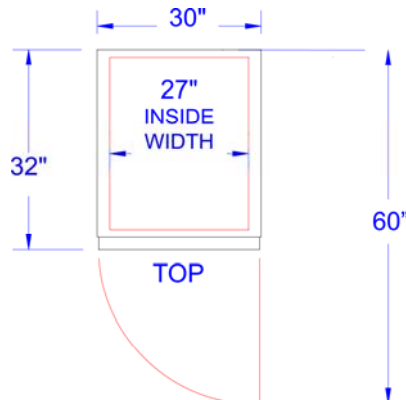
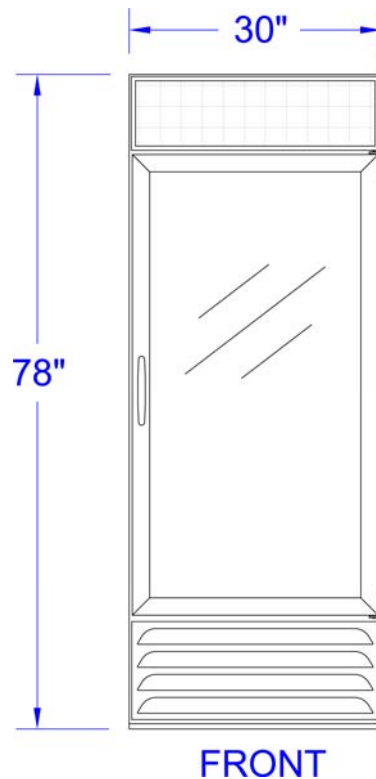
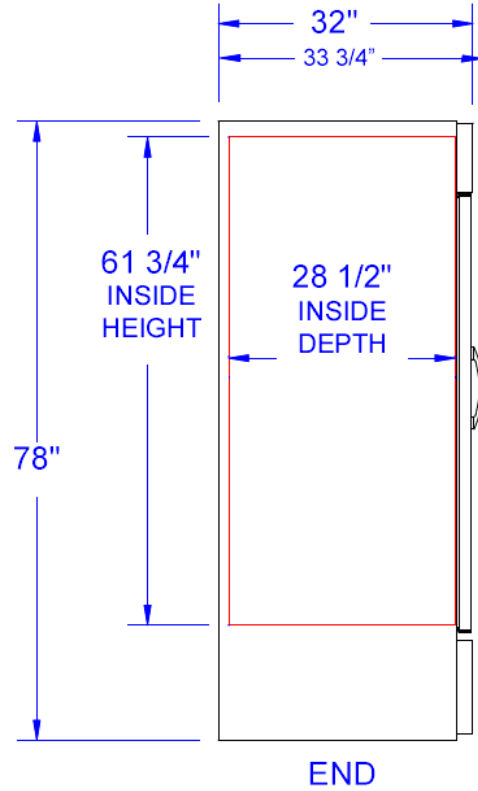

Note: Not all markings may apply to all model variations.

BEVERAGE-AIR® CORPORATION

3779 Champion Blvd. • Winston-Salem, NC 27105 USA • (336) 245-6400 • Fax (336) 245-6453 • (888) 845-9800 • www.beverage-air.com

Specifications are subject to change without prior notice. 06/13