



# BEVERAGE-AIR

3779 Champion Blvd., Winston-Salem, NC 27105  
1-888-845-9800 Fax# 1-336-245-6453  
<http://www.Beverage-Air.com>

**CUSTOMER'S CHOICE FOR A HOT LOCATION**  
**Tested & Certified to Ambient Class of 100°F**

**3 Year Parts/Labor Warranty**  
**Additional 2 Year Compressor Warranty**

## MARKETMAX™ GLASS DOOR ICE MERCHANDISER

Double section glass door ice merchandiser with lighted sign panel used for merchandising and storage of ice.

### CABINET CONSTRUCTION

Heavy duty construction includes white coated steel interior walls. White or black exterior finishes are heavy-duty steel with a baked on durable coating.

Foamed-in-place CFC and HCFC-free polyurethane insulation.  
Modern, one-piece grille is easily removed for cleaning and servicing.

Freezer models have heated triple pane glass. Inside and outside panes are tempered for added safety. Anti-microbial door handles are standard. Doors provide automatic hold-open feature.

Brightly lighted sign panel.

### STORAGE CAPACITY

Raised interior floor racks and backguards prevent bags of ice from blocking proper airflow.

Holds (117) 8 lbs. (4 kg) bags of ice.

### ELECTRONIC CONTROL

Electronic thermostat with manual defrost button provides a digital display of cabinet temperatures, which includes status indicators and key pad for any necessary temperature adjustments.

### REFRIGERATION

Self-contained bottom mount refrigeration system. Expansion valve refrigerant control on freezer provides quick temperature pull down and reduces compressor run time—meaning reduced energy consumption. Includes automatic condensate disposal. Freezers utilize ozone friendly R404A refrigerant and its defrost system is fully automatic, time-initiated and temperature terminated operation.

Freezer product temperatures from 20°F to 25°F (-6.6°C to -3.8°C).

### ELECTRICAL

Interior fluorescent lighting enhances product illumination.  
Optional LED lighting provides hidden light source for increased product visibility. LED bulbs last up to 10 times longer compared to fluorescent bulbs and renders additional energy savings due to reduced wattage load on compressor.

Freezer units wired at factory and ready for connection to a 115/60/1 phase, 20 amp dedicated outlet. 8' long cord and plug set included.

Item No. \_\_\_\_\_  
Quantity \_\_\_\_\_

## HINGED GLASS DOOR MARKETMAX™ ICE MERCHANDISER SERIES

MMF49 Freezer  
Double Door

MODELS:  
MMF49-1-B-ICE  
MMF49-1-W-ICE  
MMF49-1-B-ICE-LED  
MMF49-1-W-ICE-LED



**MMF49-1-B-ICE**  
(SHOWN IN BLACK EXTERIOR)

**MMF49-1-W-ICE**  
(SHOWN IN WHITE EXTERIOR)

### SPECIAL FEATURES

- MMF49 has earned the ENERGY STAR®
- Holds (117) 8 lbs. (4 kg) bags of ice
- Anti-microbial door handles
- Electronic control with digital display
- Brightly lighted sign panel
- Optional LED lighting
- **Available options:** S/S Exterior, Black Interior, Casters, Audible Alarm With PM Feature, Smart Defrost



115/60/1  
NEMA-5-20P  
Freezer

### ELECTRICAL CONNECTION

Units pre-wired at factory and include 8' long cord and plug set.

Available From:



\*Note: Not all markings may apply to all model variations.

<b>Model Specified</b> _____	<b>Store#</b> _____
<b>Location</b> _____	<b>Quantity</b> _____



**MarketMax™ Glass Door Ice Merchandisers**  
**Model: MMF49-1-B-ICE, MMF49-1-W-ICE**

MODEL	MMF49
<b>EXTERNAL DIMENSIONAL DATA</b>	
Length Overall (inches)	52"
Length Overall (mm)	1321
Depth Overall (inches) - includes handle	33 3/4"
Depth Overall (mm) - includes handle	857
Height Overall— (inches)	78"
Height Overall— (mm)	1981
Number of doors	2
Depth with Door Open 90 °	60"
<b>INTERNAL DIMENSIONAL DATA</b>	
NET Capacity (cubic ft.)	49
NET Capacity (Liters)	1388
Internal Length Overall (inches)	49"
Internal Length Overall (mm)	1245
Internal Depth Overall (inches)	28 1/2"
Internal Depth Overall (mm)	724
Internal Height Overall—(inches)	61 3/4"
Internal Height Overall—(mm)	1569
<b>ELECTRICAL DATA</b>	
Full Load Amperes 115/60/1	13.8 A
<b>REFRIGERATION DATA</b>	
Horsepower	3/4
<b>WEIGHT DATA</b>	
Gross Weight (Crated lbs)	560
Gross Weight (Crated kg)	254

**PLAN VIEWS**

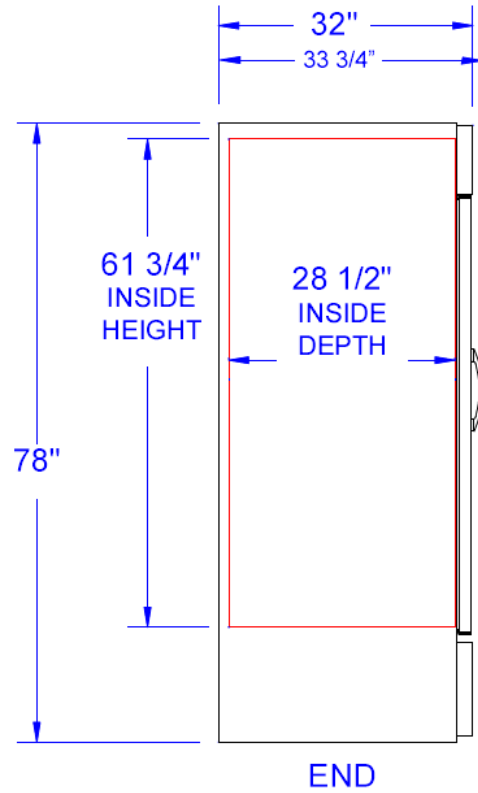

**Note:** Not all markings may apply to all model variations.

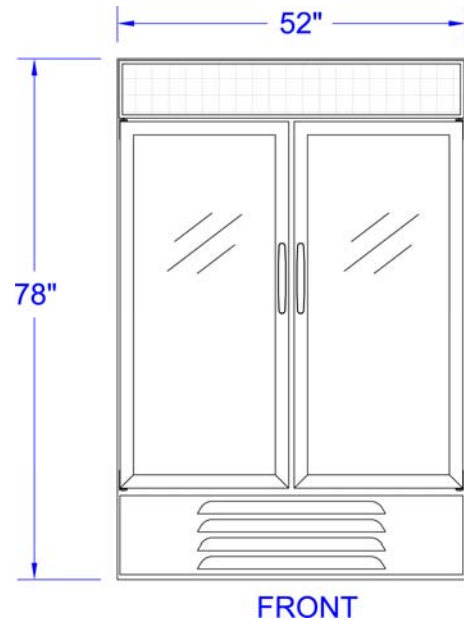
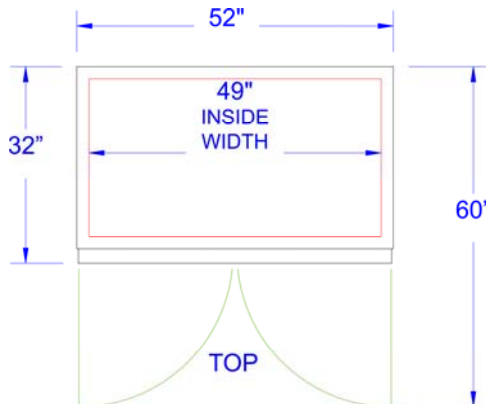

**BEVERAGE-AIR® CORPORATION**

3779 Champion Blvd. • Winston-Salem, NC 27105 USA • (336) 245-6400 • Fax (336) 245-6453 • (888) 845-9800 • www.beverage-air.com

Specifications are subject to change without prior notice. 06/13