



BEVERAGE-AIR

3779 Champion Blvd., Winston-Salem, NC 27105
1-888-845-9800 Fax# 1-336-245-6453
<http://www.Beverage-Air.com>

Commercial Refrigeration Equipment General Specification

3 Year Parts/Labor Warranty Additional 2 Year Compressor Warranty

MARKETMAX DUAL TEMPERATURE GLASS DOOR MERCHANDISERS

Double and Triple section, DUAL TEMPERATURE WINE glass door merchandisers with lighted sign panel used for merchandising and storage of product.

CABINET CONSTRUCTION

Heavy duty construction includes white coated steel interior walls. White or black exterior finishes are heavy-duty steel with a baked on durable coating. Stainless steel interior option available.

Foamed-in-place CFC and HCFC-free polyurethane insulation.

Modern, one-piece grille is easily removed for cleaning and servicing.

Anti-microbial door handles are standard.
Doors provide automatic hold-open feature.

Lighted sign panel.

SHELVING

Five (5) heavy duty epoxy coated wire shelves per section standard.
Four (4) shelf clips included per shelf (field installed).
Shelves are adjustable in 1/2" increments.

ELECTRONIC CONTROL

Electronic thermostat provides a digital display of cabinet temperatures, which includes status indicators and key pad for any necessary temperature adjustments when storing red and white wines.

REFRIGERATION

Self-contained bottom mount refrigeration system. Refrigerators utilize ozone friendly R134a refrigerant.

Each section can be adjusted to maintain product temperatures from 38°F to 60°F for proper storage of both red and white wines.

For MMRR72, 2 of the same wine storage applications must operate side-by-side. See page 2 for possible configurations.

ELECTRICAL

Interior fluorescent lighting enhances product illumination.
Optional LED lighting provides hidden light source for increased product visibility. LED bulbs last up to 10 times longer compared to fluorescent bulbs and renders additional energy savings due to reduced wattage load on compressor.

Refrigerator section(s) wired at factory and ready for connection to a 115/60/1 phase, 15 amp dedicated outlet. 8' long cord and plug set included.



115/60/1
NEMA-5-15P

ELECTRICAL CONNECTION

Units pre-wired at factory and include 8' long cord and plug set.

Item No. _____
Quantity _____

HINGED GLASS DOOR MARKETMAX® DUAL-TEMP WINE MERCHANDISER SERIES Refrigerator/Refrigerator Double and Triple Doors

MODELS:
MMRR49-1-B
MMRR49-1-W
MMRR49-1-B-LED
MMRR49-1-W-LED
MMRR72-1-B
MMRR72-1-W
MMRR72-1-B-LED
MMRR72-1-W-LED



MMRR49-1-B
(SHOWN IN BLACK EXTERIOR)
White and S/S Exterior
finishes available



MMRR72-1-B
(SHOWN IN BLACK EXTERIOR)
White and S/S Exterior
finishes available

SPECIAL FEATURES

- Easily adjust temperatures in each section to maintain 38°F to 60°F for proper storage of both red and white wines
- Anti-microbial door handles
- Electronic control with digital display
- Lighted sign panel
- Optional LED lighting
- **Available options:** S/S Exterior, Black Interior, Black Shelves, Spring Feed Dividers, Casters, Audible Alarm, Optional Headers in Black, White or Stainless, Optional Customized Graphics

Available From:



*Note: Not all markings may apply to all model variations.

Model Specified _____	Store# _____
Location _____	Quantity _____



MarketMax™ Glass Door Dual-Temp Wine Merchandisers

Model: MMRR49, MMRR72

Note: For door configurations not listed, contact factory.

MODEL	MMRR49	MMRR72
EXTERNAL DIMENSIONAL DATA		
Length Overall (inches)	52"	75"
Length Overall (mm)	1321	1905
Depth Overall (inches) - includes handle	33 3/4"	33 3/4"
Depth Overall (mm) - includes handle	857	857
Height Overall— (inches)	78"	78"
Height Overall— (mm)	1981	1981
Number of doors	2	3
Depth with Door Open 90 °	60"	55"
INTERNAL DIMENSIONAL DATA		
NET Capacity (cubic ft.)	49	72
NET Capacity (Liters)	1388	2039
Internal Length Overall (inches)	49"	72"
Internal Length Overall (mm)	1245	1829
Internal Depth Overall (inches)	28 1/2"	28 1/2"
Internal Depth Overall (mm)	724	724
Internal Height Overall—(inches)	61 3/4"	61 3/4"
Internal Height Overall—(mm)	1569	1569
Number of shelves	10	15
ELECTRICAL DATA		
Full Load Amperes 115/60/1	8.8 A*	8.8 A*
REFRIGERATION DATA		
Horsepower	1/3 *	1/3*
WEIGHT DATA		
Gross Weight (Crated lbs)	530	775
Gross Weight (Crated kg)	240	352

PLAN VIEWS

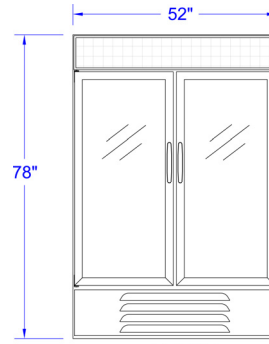

MMRR49

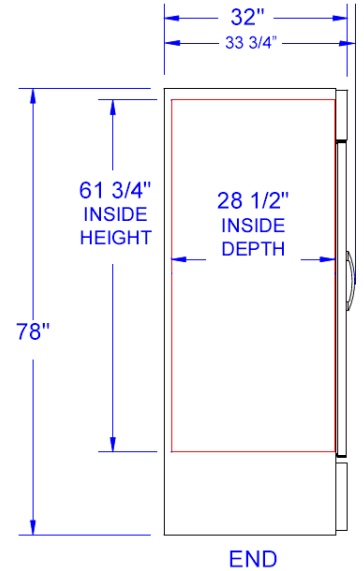

END

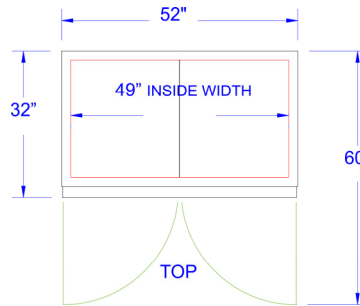

MMRR49

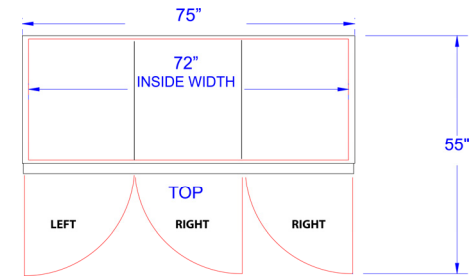

MMRR72

STANDARD DOOR HINGE TEMPLATE SHOWN
(FOR ADDITIONAL HINGE OPTIONS, CONTACT FACTORY.)



*Note: Amps & hp subject to change based on door configurations.
*Note: Not all markings may apply to all model variations.

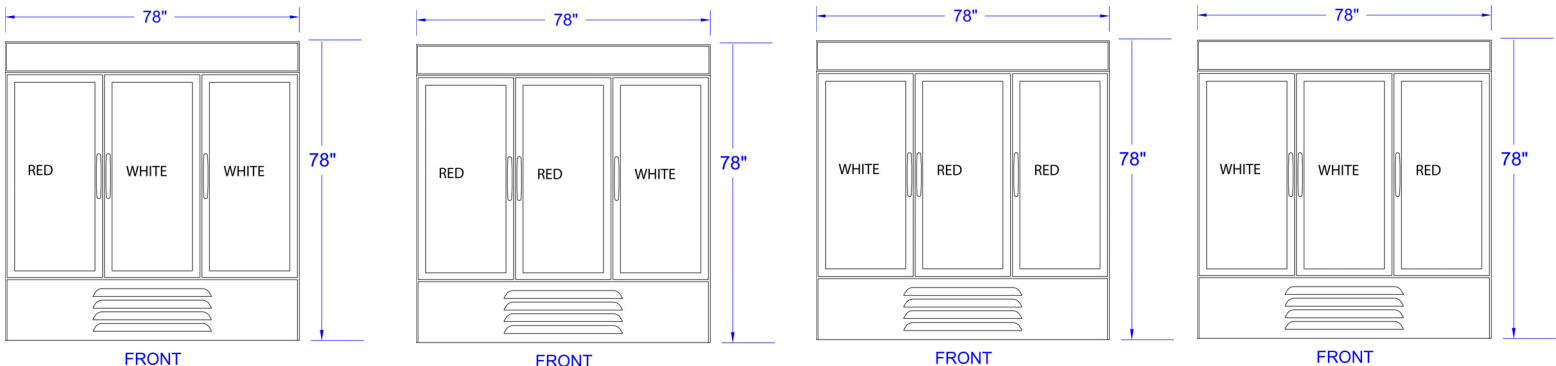

CONFIGURATIONS (For MMRR72, 2 of the same wine storage applications must operate side-by-side)

BEVERAGE-AIR® CORPORATION

3779 Champion Blvd. • Winston-Salem, NC 27105 USA • (336) 245-6400 • Fax (336) 245-6453 • (888) 845-9800 • www.beverage-air.com

Specifications are subject to change without prior notice. 07/13