



BEVERAGE-AIR

3779 Champion Blvd., Winston-Salem, NC 27105
1-888-845-9800 Fax# 1-336-245-6453
<http://www.Beverage-Air.com>

CUSTOMER'S CHOICE FOR A HOT KITCHEN
Tested & Certified to Ambient Class of 100°F

3 Year Parts/Labor Warranty Additional 2 Year Compressor Warranty

SPE72 ELITE SERIES — MEGA TOP WITH SEE-THRU LID

Fifty percent greater pan capacity than the all around standard prep table. Features enhanced refrigeration system and new and improved grille system for better airflow and less temperature gradient. Improved design provides better airflow management and uniform temperature distribution throughout the cabinet. Pans are cooled from the bottom, eliminating the necessity of air blanket. Airflow assures that product in open containers is kept below 41°F and above freezing. This translates into increased product shelf life, higher quality food, better food appearance, fresher product and a reduction of bacteria build-up to combat food-borne illnesses.

CABINET CONSTRUCTION

Exterior construction includes heavy-duty stainless steel finish on front, sides, top, door(s) and grille. Removable hoods and insulated lid assemblies are made of matching stainless steel. Cabinet back and bottom are constructed of galvanized steel. Interior liner is made of aluminum for superior resistance to corrosion.

Doors are mounted to face of cabinet on cartridge style hinges permitting them to self close under their own weight. Hinges also allow doors to stay open 120° and permit easy door removal for service and cleaning if required. A plug in type vinyl magnetic gasket is attached to each door for positive seal. Door handle is made from extruded aluminum with a black anodized finish. It is contoured to permit easy opening of doors with fingers from both top and bottom of handle.

Cabinet insulation is CFC free foamed-in-place polyurethane of two-inch minimum thickness. Six-inch casters, 2 with brakes, are standard. Legs are available as an option.

Cutting board supplied with cabinet is 10" deep constructed of high-density white polyethylene plastic. It is readily removable for cleaning. Two epoxy-coated steel wire shelves per section are supplied as standard. Pans furnished are 4" deep and made of polycarbonate plastic.

See-Thru Lid Construction

Features 1-piece hinge with hydraulic lift. Self-closing lid features variable set points for height variations.

Note: If sides are exposed to customer, side guards are required.

REFRIGERATION

More robust refrigeration system provides added capacity and efficiency. Systems are designed using CFC free R134a refrigerant and capillary tube between condenser and evaporator. Recirculated, forced air from evaporator is moved under pans, which are recessed 2" from top of cabinet. Forced air over the condenser is drawn through grille under door as well as the back and bottom of cabinet. Automatic condensate evaporator is provided to eliminate the need of floor drains.

Item No. _____
Quantity _____

**FOOD PREPARATION
SERIES PREP TABLES**
SPE72 ELITE SERIES
MEGA TOP
WITH SEE-THRU GLASS LID

MODELS:
SPE72-30M-STL



SPE72-30M-STL
(60" UNIT SHOWN WITH
SEE-THRU GLASS LID)



ELECTRICAL CONNECTION

Units pre-wired at factory and include 8' long cord and plug



Available From:



*Note: Not all markings may apply to all model variations.

Model Specified _____	Store# _____
Location _____	Quantity _____



Food Preparation Table — Mega Top
Models: SPE72-30M-STL With See-Thru Lid

PLAN VIEWS

MODEL	SPE72-30M-STL
EXTERNAL DIMENSIONAL DATA	
Length Overall (inches)	72"
Length Overall (mm)	1829
Depth Overall (inches)	37 7/8"
Depth Overall (mm)	962
Height Overall—(inches)	37 5/8"
Height Overall—(mm)	956
Number of doors	3
Depth with Door Open 90 °	53 3/4"
Clear Door Opening (inches)	22 1/2" x 21 1/2"
INTERNAL DIMENSIONAL DATA	
NET Capacity (cubic ft.)	21.5
NET Capacity (Liters)	609
Internal Length Overall (inches)	68"
Internal Length Overall (mm)	1727
Internal Depth Overall (inches)	19 1/4"
Internal Depth Overall (mm)	489
Internal Height Overall—(inches)	17 1/2"
Internal Height Overall—(mm)	445
Number of shelves	6
ELECTRICAL DATA	
Full Load Amperes 115/60/1	9.6
REFRIGERATION DATA	
Horsepower	1/3
WEIGHT DATA	
Gross Weight (Crated lbs)	415
Gross Weight (Crated kg)	188

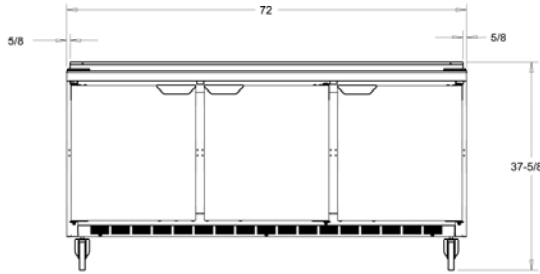

SPE72-30M-STL
FRONT VIEW
WITH LID CLOSED

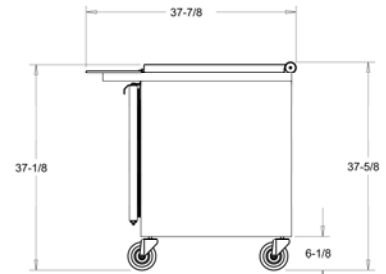

SPE72-30M-STL
END VIEW
WITH LID CLOSED

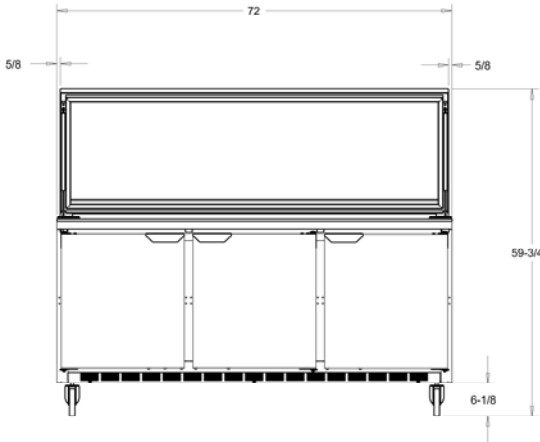

SPE72-30M-STL
FRONT VIEW
WITH LID OPEN

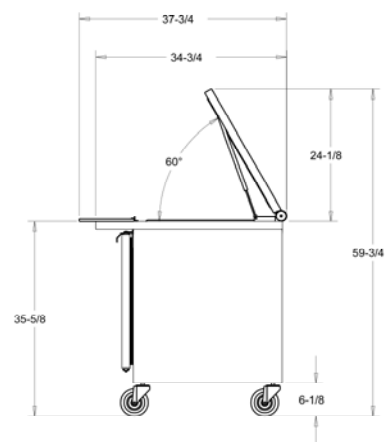

SPE72-30M-STL
END VIEW
WITH LID OPEN



*Note: Not all markings may apply to all model variations.

SPE72-30M-STL
TOP VIEW

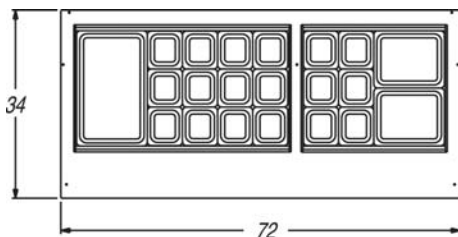

BEVERAGE-AIR® CORPORATION

3779 Champion Blvd. • Winston-Salem, NC 27105 USA • (336) 245-6400 • Fax (336) 245-6453 • (888) 845-9800 • www.beverage-air.com

Specifications are subject to change without prior notice. 06/13