



BEVERAGE-AIR

3779 Champion Blvd., Winston-Salem, NC 27105
1-888-845-9800 Fax# 1-336-245-6453
<http://www.Beverage-Air.com>

Commercial Refrigeration Equipment General Specification

3 Year Parts/Labor Warranty Additional 2 Year Compressor Warranty

VUEMAX SERIES—OPEN-AIR MERCHANDISERS

Three different sizes to choose from (7, 12, 15 or 18 cubic feet).
Certified for packaged product. Ideal for gourmet shops, delicatessens, convenience stores and bakeries.

CABINET CONSTRUCTION

Exterior finish is heavy-duty steel with a baked on durable paint.
Gray exterior finish with stylish impact bumper for added protection.

Foamed-in-place CFC free polyurethane insulation enhances the structural strength of the cabinet and helps increase energy efficiency.

Glass sides constructed to enhance product visibility from different angles.

Shelves included can be installed in 2 positions for display flexibility.

Night curtain comes standard and helps save energy and maintain cabinet temperature.

6" adjustable legs standard.

REFRIGERATION

Whisper-quiet refrigeration system uses R134a refrigerant, which is CFC-free for compliance with environmental safety concerns. Maintenance-free condenser slides out for easy service.

Electronic temperature control displays internal cabinet temperatures. Operating temperatures from 36°F to 40°F.

Intended for use in rooms having ambient conditions of 75°F/55% relative humidity.

ELECTRICAL

Excellent interior lighting enhances product illumination.

SPECIAL FEATURES

- Night curtain standard
- Stylish impact bumper
- 6" adjustable legs standard
- 5" casters (optional) add versatility
- Security cover (optional) helps keep your merchandise secure outside normal business hours.
- Custom graphics available. Contact factory for more information.



SECURITY CAGE



NIGHTBLIND

Item No. _____
Quantity _____

VUEMAX OPEN-AIR MERCHANDISER SERIES

VUEMAX is certified for
bottled beverage and
packaged food product

MODELS:
VM7
VM12
VM15
VM18



VM7



VM12



VM15



VM18



Gray exterior is standard. Black and white exterior options are available. Contact factory for availability and lead time.

Available From:



Model Specified _____

Store# _____

Location _____

Quantity _____



BEVERAGE-AIR

VueMax Open-Air Merchandisers

Models: VM7, VM12, VM15, VM18

PLAN VIEWS

MODEL	VM7	VM12	VM15	VM18
EXTERNAL DIMENSIONAL DATA				
Length Overall (inches)	35"	35"	51"	51"
Length Overall (mm)	889	889	1295	1295
Depth Overall (inches)	31"	31"	31"	31"
Depth Overall (mm)	787	787	787	787
Height Overall— (inches)	59"	79"	59"	79"
Height Overall— (mm)	1499	2007	1499	2007
INTERNAL DIMENSIONAL DATA				
NET Capacity (cubic ft.)	7	12	15	18
NET Capacity (Liters)	198	340	424	510
Number of shelves	3	4	4	4
ELECTRICAL DATA				
Full Load Amperes 115/60/1—Breaker required	15	20	20	20
Amp Draw	8	11	16	16
REFRIGERATION DATA				
Horsepower	1/3	2 of 1/4	2 of 1/3	2 of 1/3
WEIGHT DATA				
Gross Weight (Crated lbs)	415	507	510	525
Gross Weight (Crated kg)	188	230	231	238



VM7

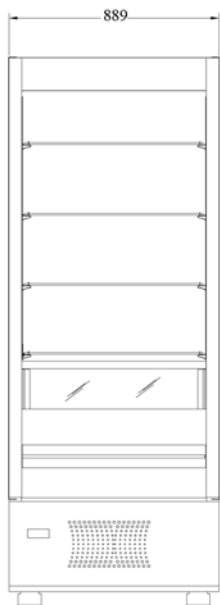
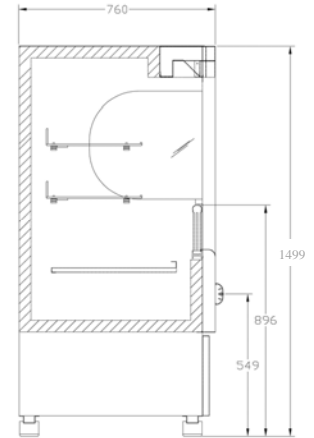

VM12

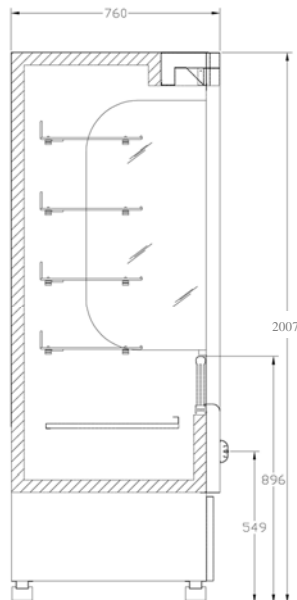

VM18

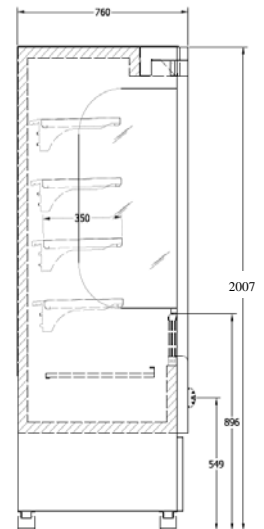

BEVERAGE-AIR® CORPORATION

3779 Champion Blvd. • Winston-Salem, NC 27105 USA • (336) 245-6400 • Fax (336) 245-6453 • (888) 845-9800 • www.beverage-air.com

Specifications are subject to change without prior notice. 08/13