



# BEVERAGE-AIR

3779 Champion Blvd., Winston-Salem, NC 27105  
1-888-845-9800 Fax# 1-336-245-6453  
<http://www.Beverage-Air.com>

Item No. \_\_\_\_\_  
Quantity \_\_\_\_\_

**WORKTOP FREEZER  
FOOD PREPARATION SERIES**

**MODELS:  
WTF60A**

**CUSTOMER'S CHOICE FOR A HOT KITCHEN**  
*Tested & Certified to Ambient Class of 100°F*

## **3 Year Parts/Labor Warranty Additional 2 Year Compressor Warranty**

### **WTF—SERIES WORKTOP UNITS**

Versatile models with stainless steel work tops and frozen storage of food products. Working height\* is 35 1/2".

### **CABINET CONSTRUCTION**

Heavy duty construction includes stainless steel on front, sides, door(s) and grille. Worktop is stainless steel with 4" removable backsplash. Cabinet back and bottom are galvanized steel. Interior liner is made of aluminum for longer lasting corrosion protection. Interior thermometer is standard.

Cabinets are insulated with foamed-in-place polyurethane insulation of 2" minimum thickness. Work tops are 2 1/2". Doors are mounted to cabinet on self-closing, cartridge style hinges with 120° stay open feature. Door openings include low wattage, anti-condensate heaters. A plug-in type vinyl magnetic gasket is attached to each door for positive seal. Convenient, contoured, pull handle is made of black anodized aluminum. Interior arrangement includes 2 steel wire epoxy coated shelves behind each door, adjustable in 1/2 inch increments.

### **REFRIGERATION**

Forced air refrigeration systems use capillary tube to meter refrigerant. Temperatures are held at zero and below. Refrigerant used is R404A. Automatic defrost is standard. Automatic (non-electric) condensate evaporator is provided.

### **ELECTRICAL**

Units wired at factory and ready for connection to a 115/60/1 phase, 15 amp dedicated outlet. 8' long cord and plug set included.

### **SPECIAL FEATURES**

- Cartridge style door hinges provides positive seal & eliminates door sagging issues (excludes glass door and some special units).
- 6" casters, two with brakes standard.
- Optional 6" legs or 3" casters available



**WTF60A**

### **ELECTRICAL CONNECTION**

Units pre-wired at factory and include 8' long cord and plug set.



115/60/1  
NEMA-5-15P

**\*Note:** Overall heights of casters may vary with different types of casters depending upon caster manufacturer designations.

Available From:



<b>Model Specified</b> _____	<b>Store#</b> _____
<b>Location</b> _____	<b>Quantity</b> _____



**BEVERAGE-AIR**

**Standard Worktop  
Freezer Cabinets  
Models: WTF60A**

MODEL	WTF60A
<b>EXTERNAL DIMENSIONAL DATA</b>	
Length Overall (inches) Length Overall (mm)	60" 914
Depth Overall (inches) - Less handle Depth Overall (mm) - Less handle	29 1/2" 749
Height Overall—on 6" casters (inches)* Height Overall—on 6" casters (mm)*	34 1/2" 876
Depth with Door Open 90 °	55 1/4"
Clear Door Opening (inches)	21 1/4"H x 22 1/4"W
Number of doors	2
<b>INTERNAL DIMENSIONAL DATA</b>	
NET Capacity (cubic ft.) NET Capacity (Liters)	13.3 376
Internal Length Overall (inches) Internal Length Overall (mm)	56" 1422
Internal Depth Overall (inches) Internal Depth Overall (mm)	15.25" 387
Internal Height Overall (inches) Internal Height Overall (mm)	23" 584
Number of shelves	2
<b>ELECTRICAL DATA</b>	
Full Load Amperes 115/60/1	9.0
<b>ENERGY CONSUMPTION (KWH)</b>	
	N/A
<b>REFRIGERATION DATA</b>	
Horsepower	1/3
<b>WEIGHT DATA</b>	
Gross Weight (Crated lbs)	265
Gross Weight (Crated kg)	120

**PLAN VIEWS**

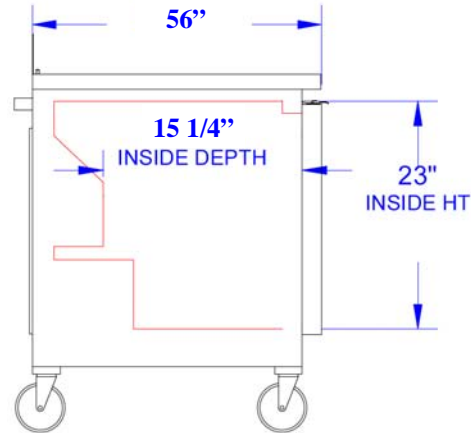
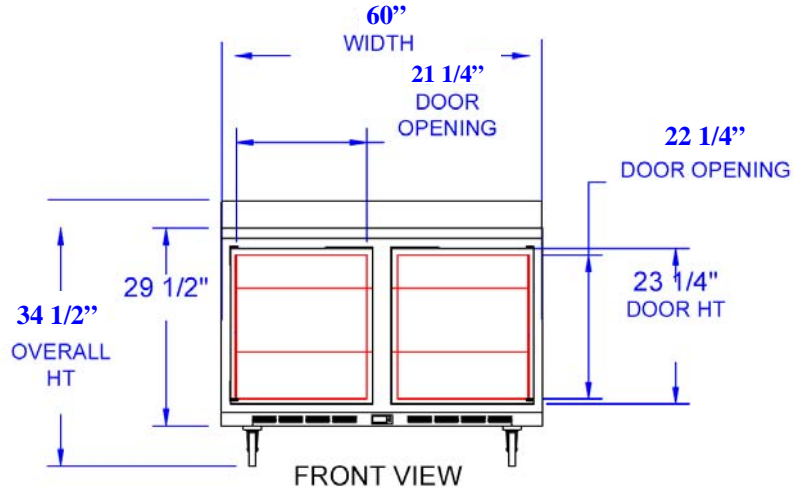

**\*Note:** Overall heights of casters may vary with different types of casters depending upon caster manufacturer designations.



**BEVERAGE-AIR® CORPORATION**

3779 Champion Blvd. • Winston-Salem, NC 27105 USA • (336) 245-6400 • Fax (336) 245-6453 • (888) 845-9800 • www.beverage-air.com

Specifications are subject to change without prior notice. 12/13